

# DERELI

ALÜMİNYUM A.Ş.

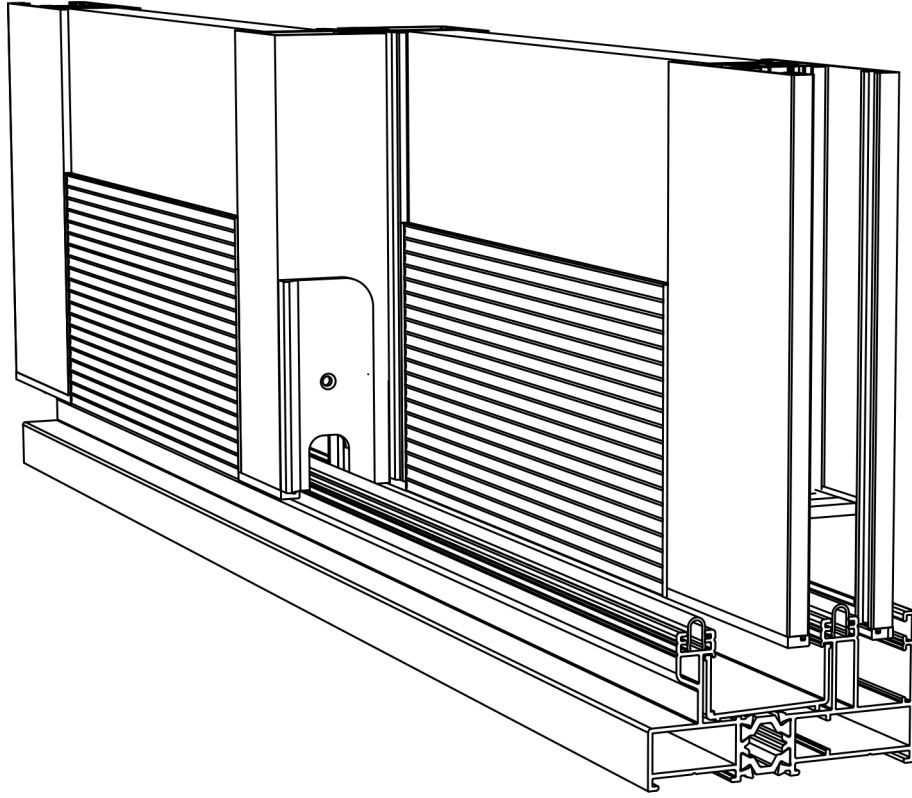

32-ST YALITIMLI SÜRME SİSTEM SERİSİ  
32-ST INSULATED SLIDE SYSTEM  
SERIES

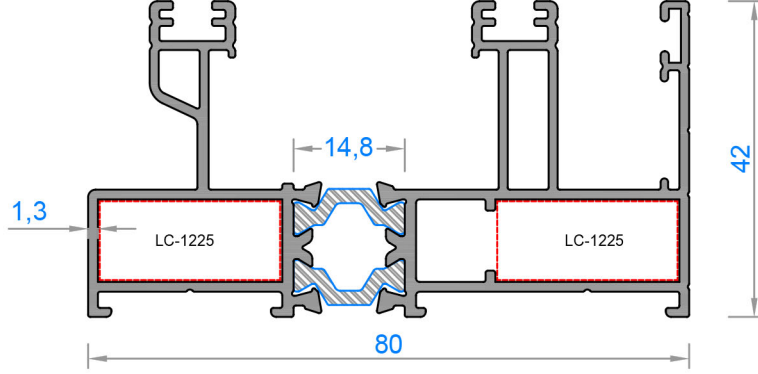

Sistem Kodu	7600-7601
Ağırlık (kg/mt)	1,500
Statik Jx (cm <sup>4</sup> )	7,98
Statik Jy (cm <sup>4</sup> )	32,13

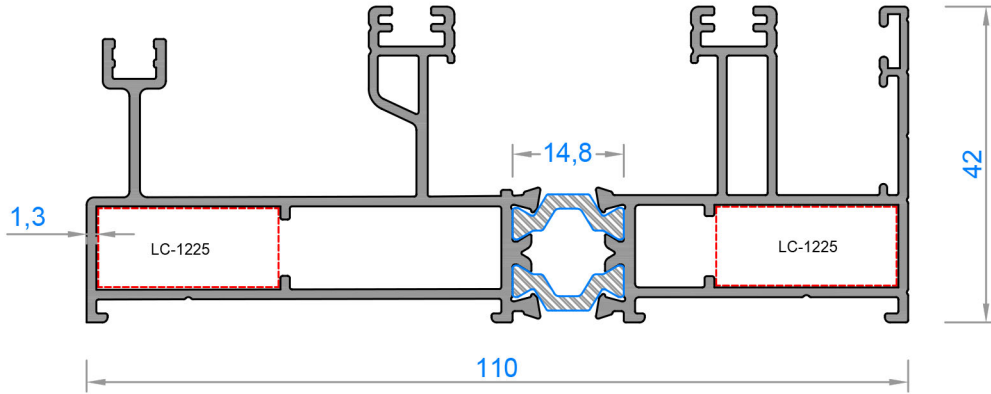

Sistem Kodu	7602-7601
Ağırlık (kg/mt)	1,838
Statik Jx (cm <sup>4</sup> )	9,60
Statik Jy (cm <sup>4</sup> )	72,80

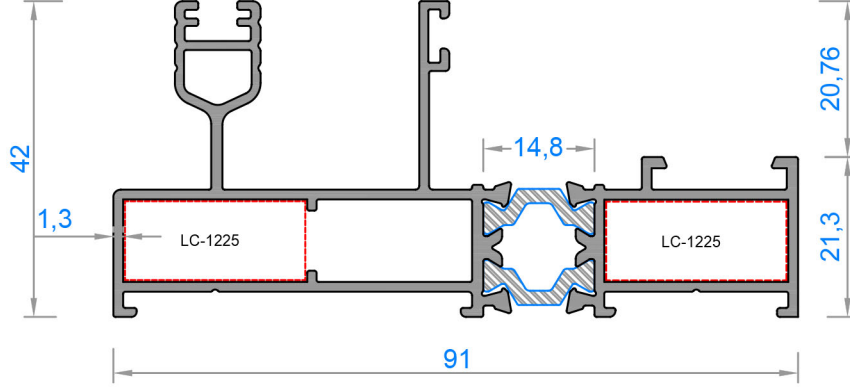

Sistem Kodu	7603-7604
Ağırlık (kg/mt)	1,410
Statik Jx (cm <sup>4</sup> )	5,50
Statik Jy (cm <sup>4</sup> )	36,30

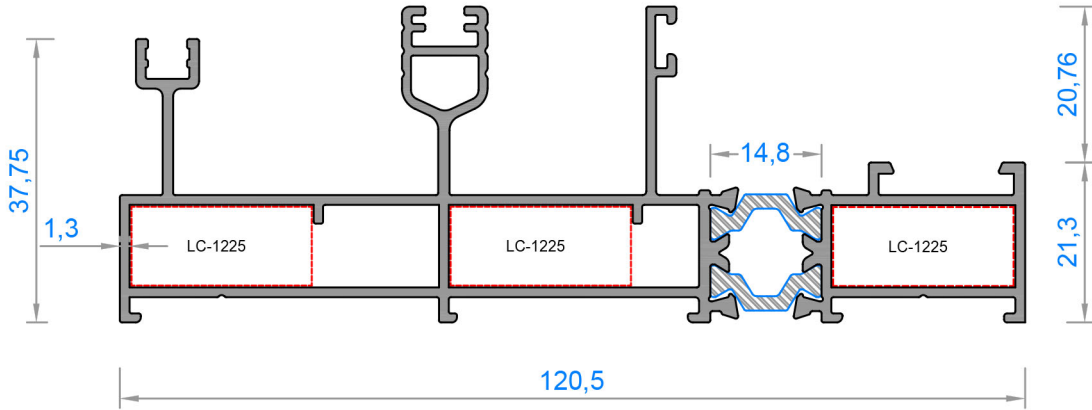

Sistem Kodu	7605-7604
Ağırlık (kg/mt)	1,800
Statik Jx (cm <sup>4</sup> )	7,45
Statik Jy (cm <sup>4</sup> )	78,6

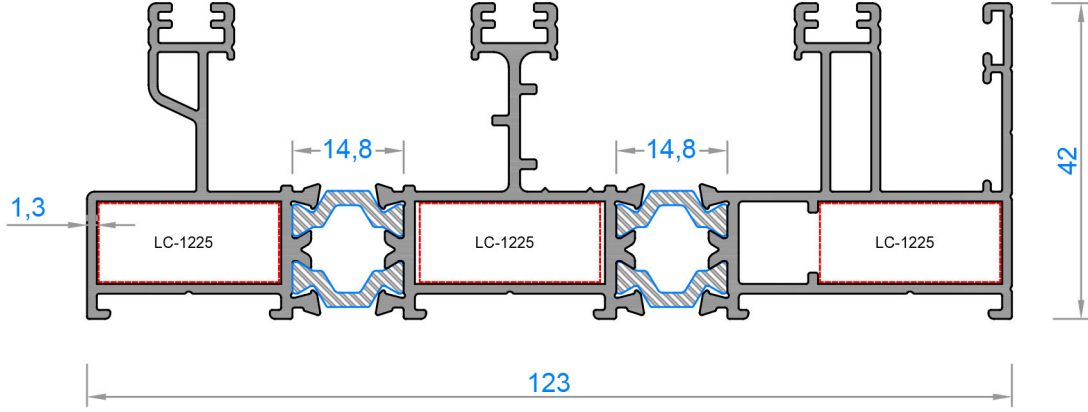

Sistem Kodu 7600-7606-7601

Ağırlık (kg/mt) 2,290

Statik Jx (cm<sup>4</sup>) 11,68

Statik Jy (cm<sup>4</sup>) 107,25

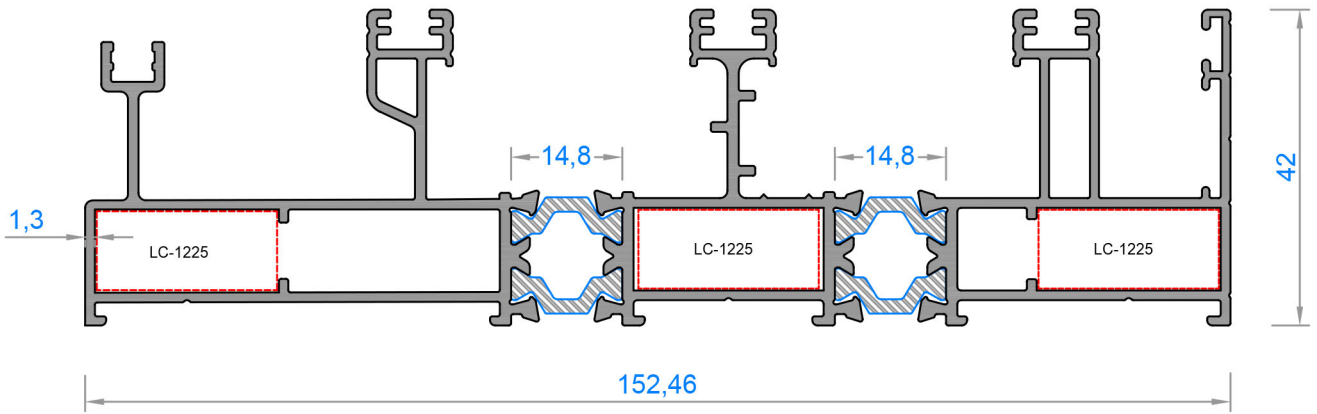

Sistem Kodu 7602-7606-7601

Ağırlık (kg/mt) 2,630

Statik Jx (cm<sup>4</sup>) 13,28

Statik Jy (cm<sup>4</sup>) 185,05

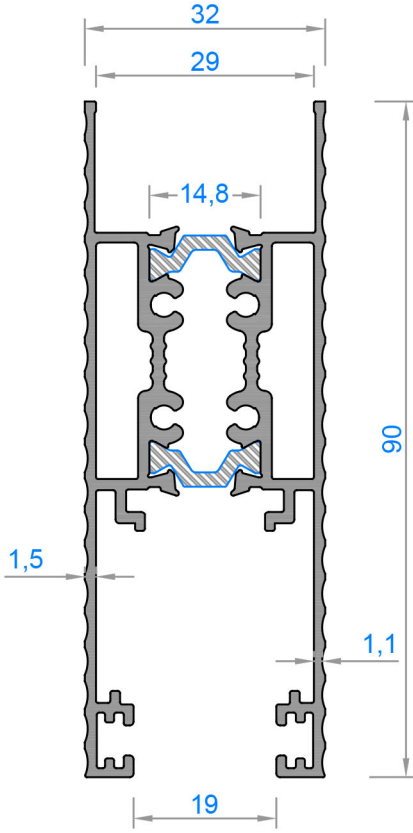

Sistem Kodu **7607-7607**

Ağırlık (kg/mt) **1,582**

Statik Jx (cm<sup>4</sup>) **27,82**

Statik Jy (cm<sup>4</sup>) **7,43**

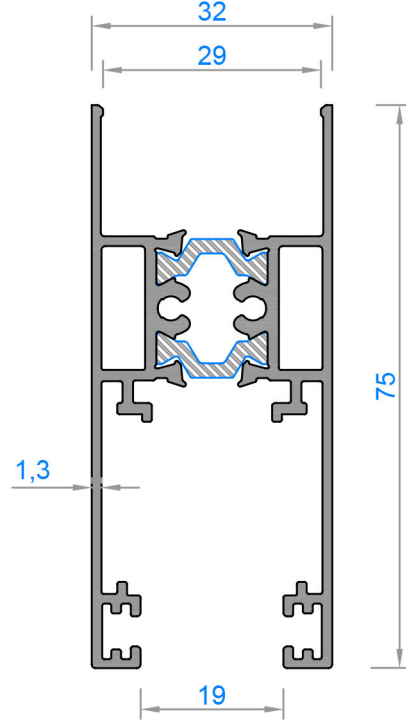

Sistem Kodu **7608-7608**

Ağırlık (kg/mt) **1,272**

Statik Jx (cm<sup>4</sup>) **16,10**

Statik Jy (cm<sup>4</sup>) **6,52**

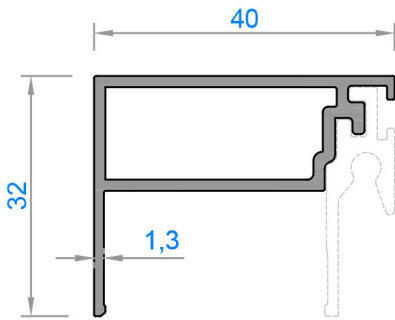

Sistem Kodu **7609**

Ağırlık (kg/mt) **0,484**

Statik Jx (cm<sup>4</sup>) **3,38**

Statik Jy (cm<sup>4</sup>) **0,87**

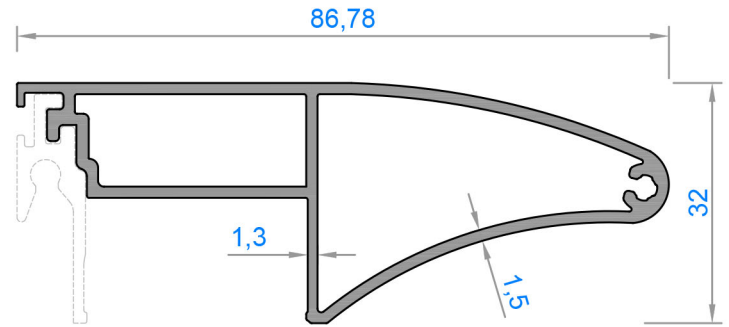

Sistem Kodu **7610**

Ağırlık (kg/mt) **0,926**

Statik Jx (cm<sup>4</sup>) **21,66**

Statik Jy (cm<sup>4</sup>) **2,42**

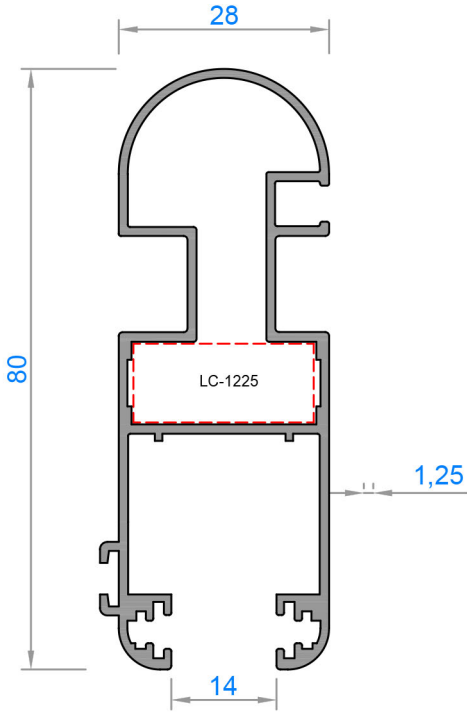

Sistem Kodu	7611
Ağırlık (kg/mt)	0,966
Statik <i>Static</i> Jx (cm <sup>4</sup> )	20,40
Jy (cm <sup>4</sup> )	4,10

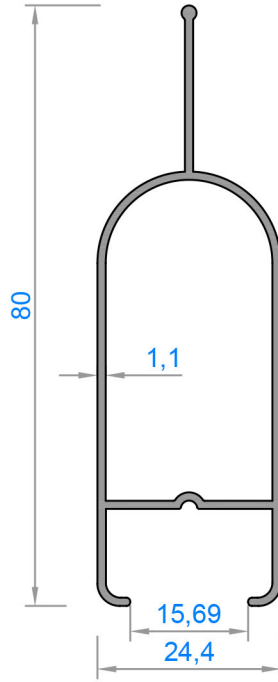

Sistem Kodu	7612
Ağırlık (kg/mt)	0,532
Statik <i>Static</i> Jx (cm <sup>4</sup> )	9,38
Jy (cm <sup>4</sup> )	1,77

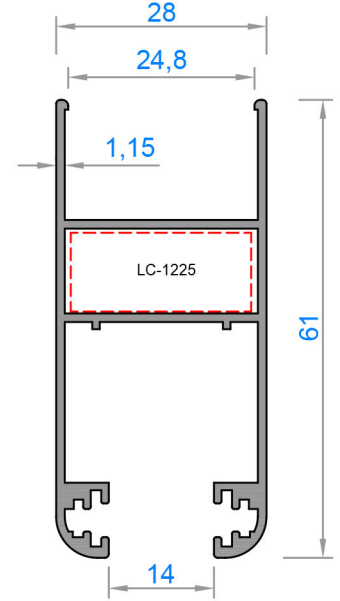

Sistem Kodu	4906
Ağırlık (kg/mt)	0,680
Statik <i>Static</i> Jx (cm <sup>4</sup> )	7,80
Jy (cm <sup>4</sup> )	3,33

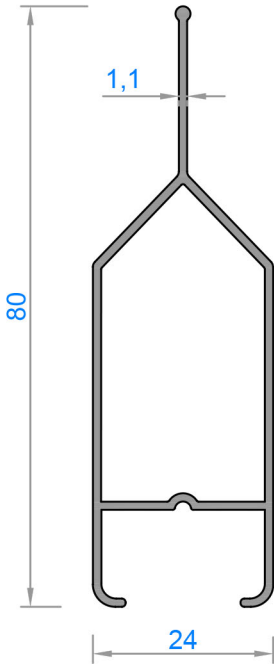

Sistem Kodu	7613
Ağırlık (kg/mt)	0,528
Statik <i>Static</i> Jx (cm <sup>4</sup> )	9,07

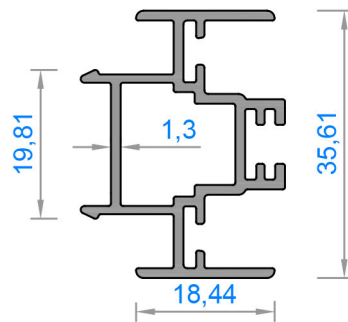

Sistem Kodu	7614
Ağırlık (kg/mt)	0,530
Statik <i>Static</i> Jx (cm <sup>4</sup> )	2,35

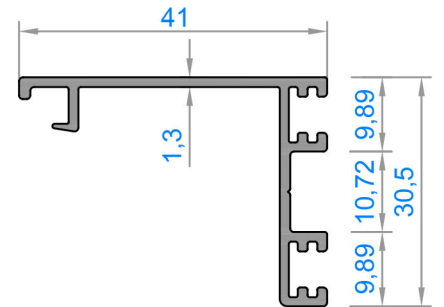

Sistem Kodu	7615
Ağırlık (kg/mt)	0,362
Statik <i>Static</i> Jx (cm <sup>4</sup> )	2,84

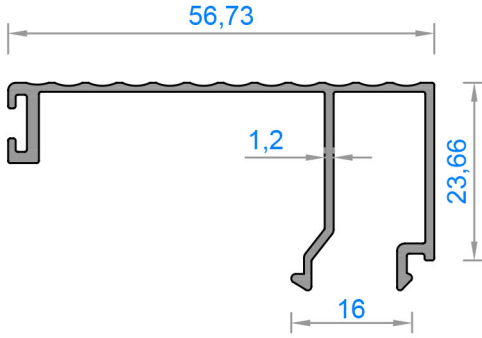

Sistem Kodu	7616
Ağırlık (kg/mt)	0,415
Statik Jx (cm <sup>4</sup> )	0,92
Statik Jy (cm <sup>4</sup> )	6,30

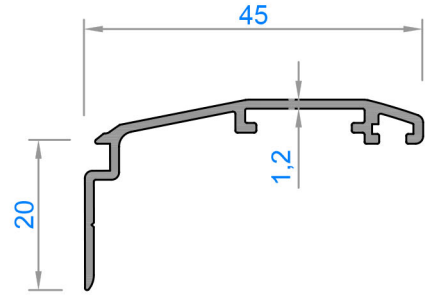

Sistem Kodu	7617
Ağırlık (kg/mt)	0,273
Statik Jx (cm <sup>4</sup> )	2,58
Statik Jy (cm <sup>4</sup> )	0,21

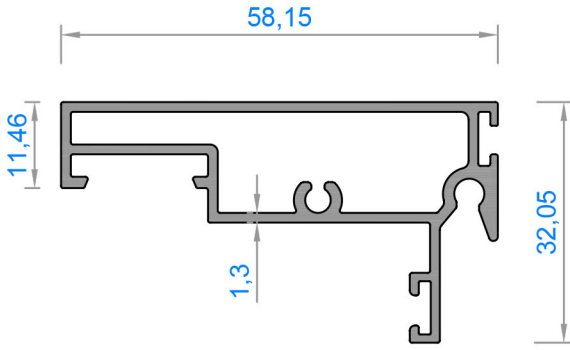

Sistem Kodu	7618
Ağırlık (kg/mt)	0,710
Statik Jx (cm <sup>4</sup> )	9,23
Statik Jy (cm <sup>4</sup> )	1,40

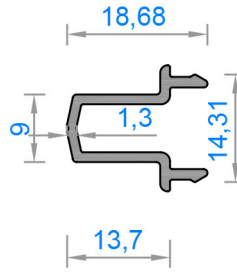

Sistem Kodu	4915
Ağırlık (kg/mt)	0,177

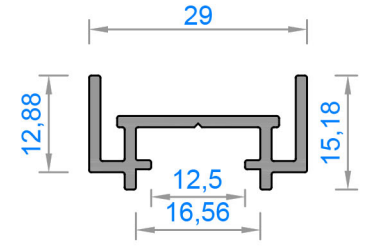

Sistem Kodu	7619
Ağırlık (kg/mt)	0,300

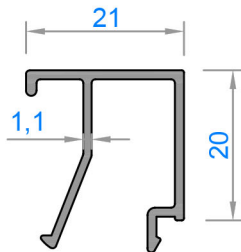

Sistem Kodu	7620
Ağırlık (kg/mt)	0,238

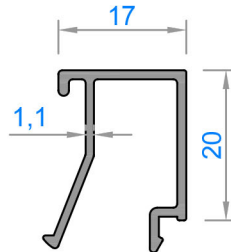

Sistem Kodu	7621
Ağırlık (kg/mt)	0,225

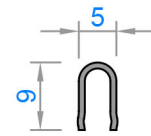

ÇELİK RAY  
STEEL RAIL

ALYAN KÖŞE BİRLEŞTİRME - IMPORTED CORNER JOINT

AS-219

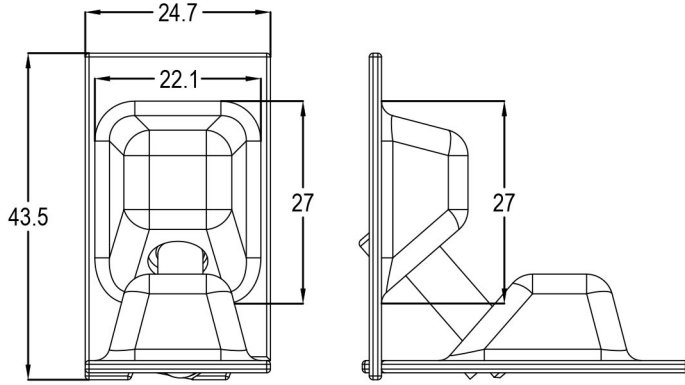

AS-219

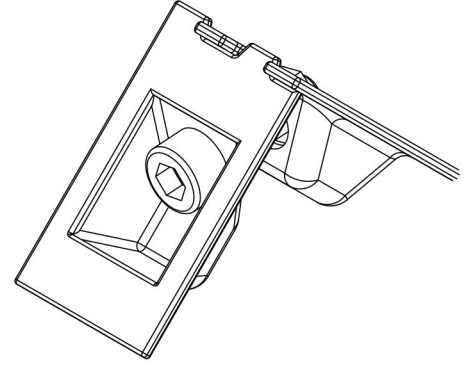

LS - 1125

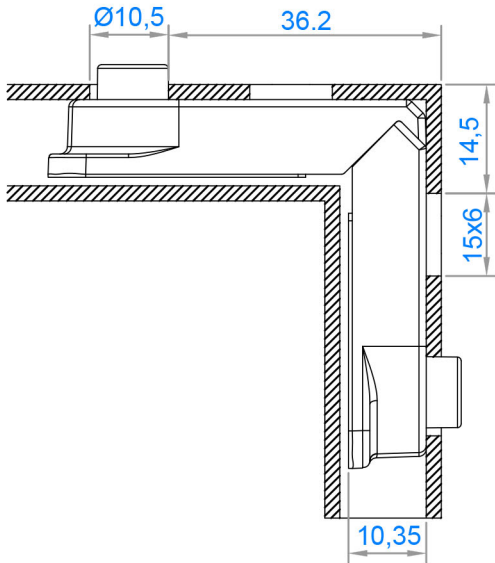

LS - 1125

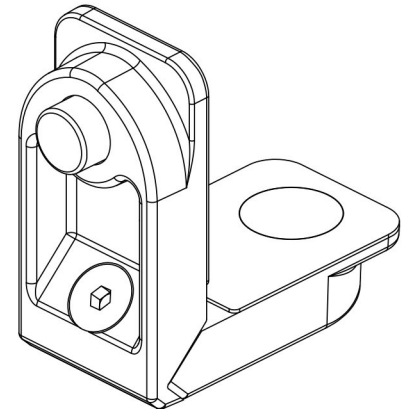
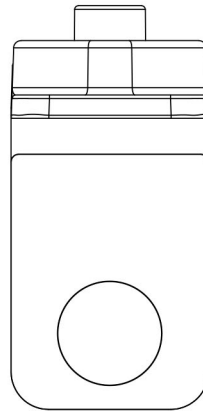



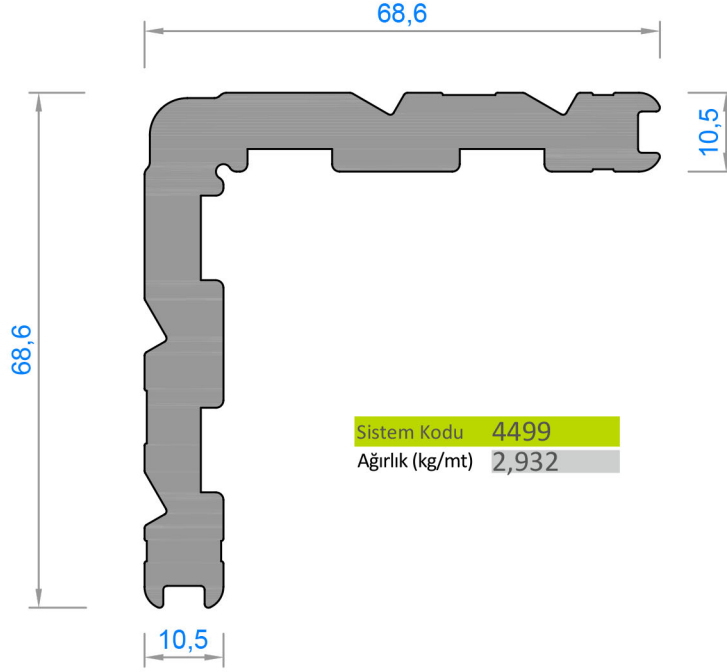

**KÖŞE TAKOZLARI (CORNER JOINT)**

Nr		AKS KODU ACS. CODE	KESİM ÖLÇÜSÜ CUTTING SIZE
SS01-SS02	4499	4499 - 24	24 mm
	4499	4499 - 24	24 mm
SS03-SS02	4499	4499 - 24	24 mm
	4499	4499 - 24	24 mm
SS04-SS05	4499	4499 - 24	24 mm
	4499	4499 - 24	24 mm
SS06-SS05	4499	4499 - 24	24 mm
	4499	4499 - 24	24 mm
	4499	4499 - 24	24 mm
SS01-SS07-SS02	4499	4499 - 24	24 mm
	4499	4499 - 24	24 mm
	4499	4499 - 24	24 mm
SS03-SS07-SS02	4499	4499 - 24	24 mm
	4499	4499 - 24	24 mm
	4499	4499 - 24	24 mm

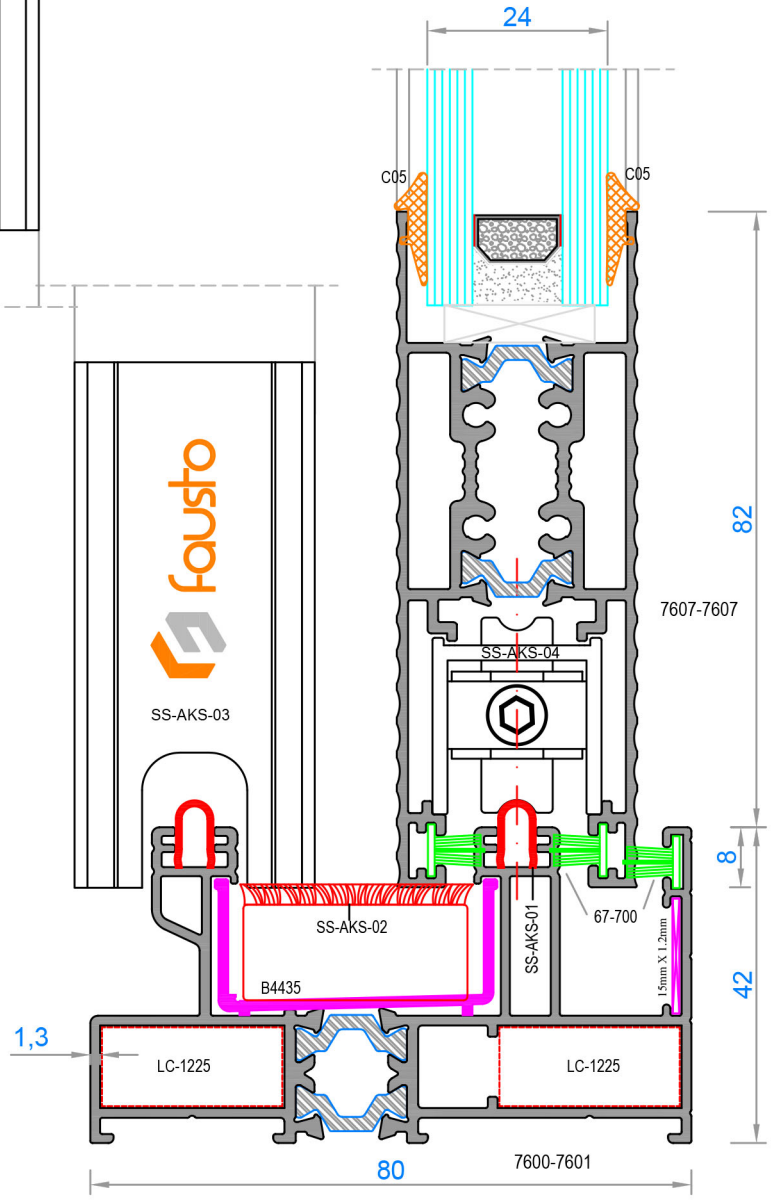
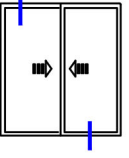
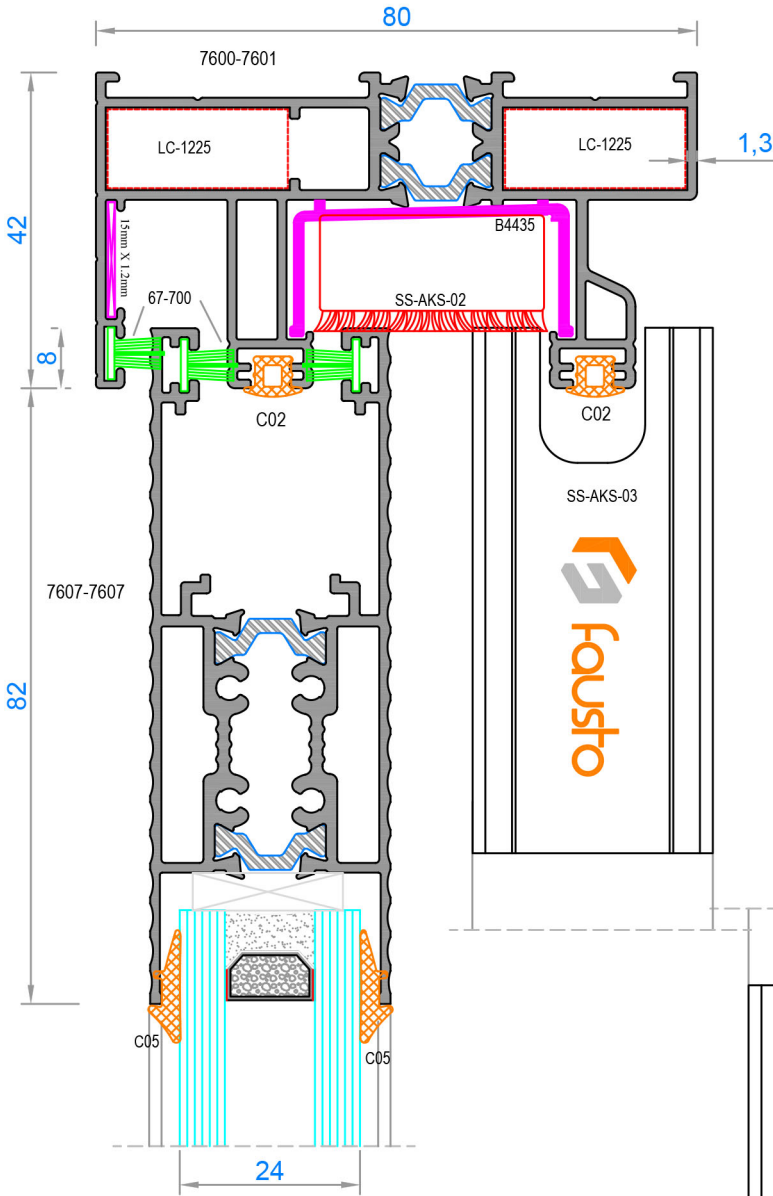

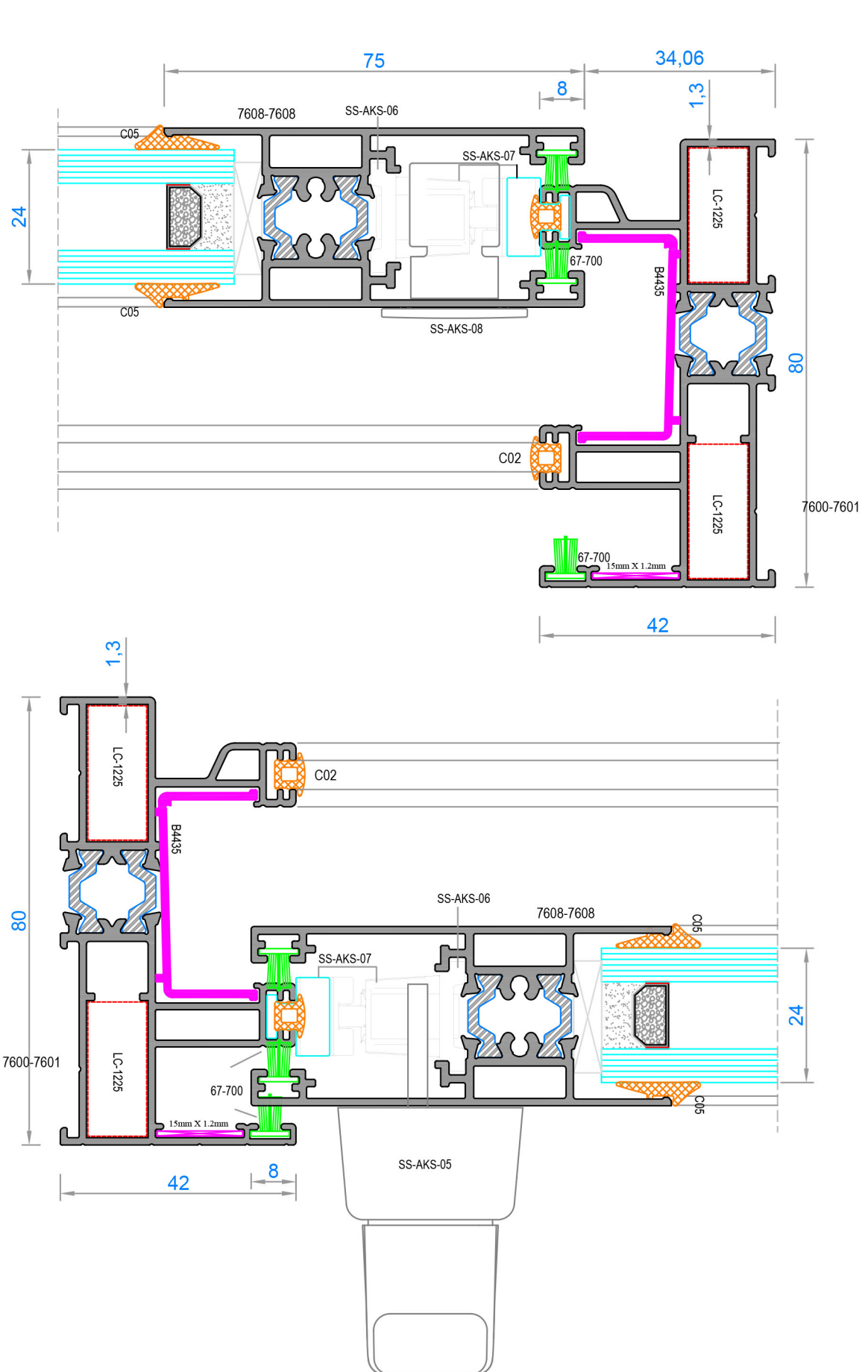

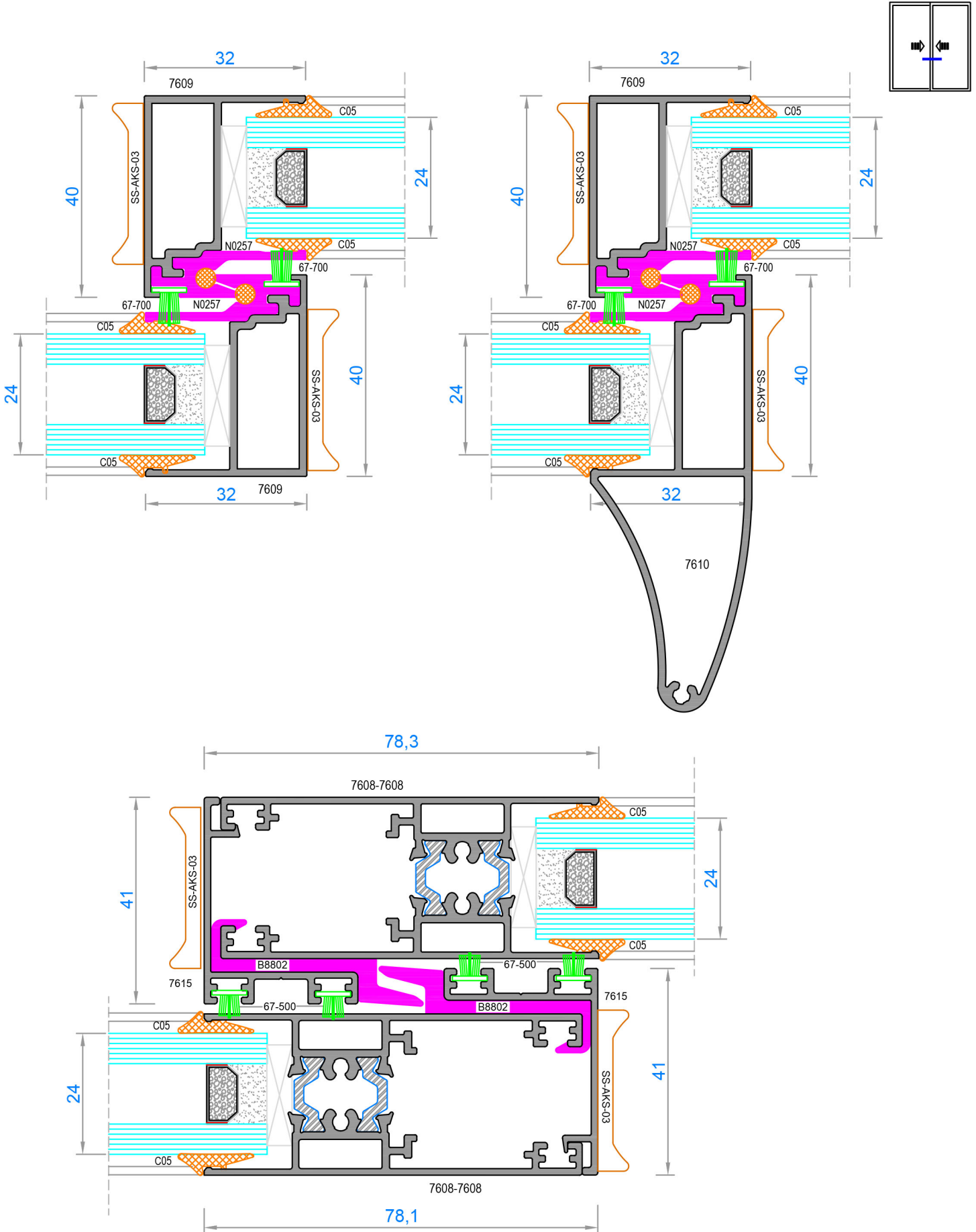

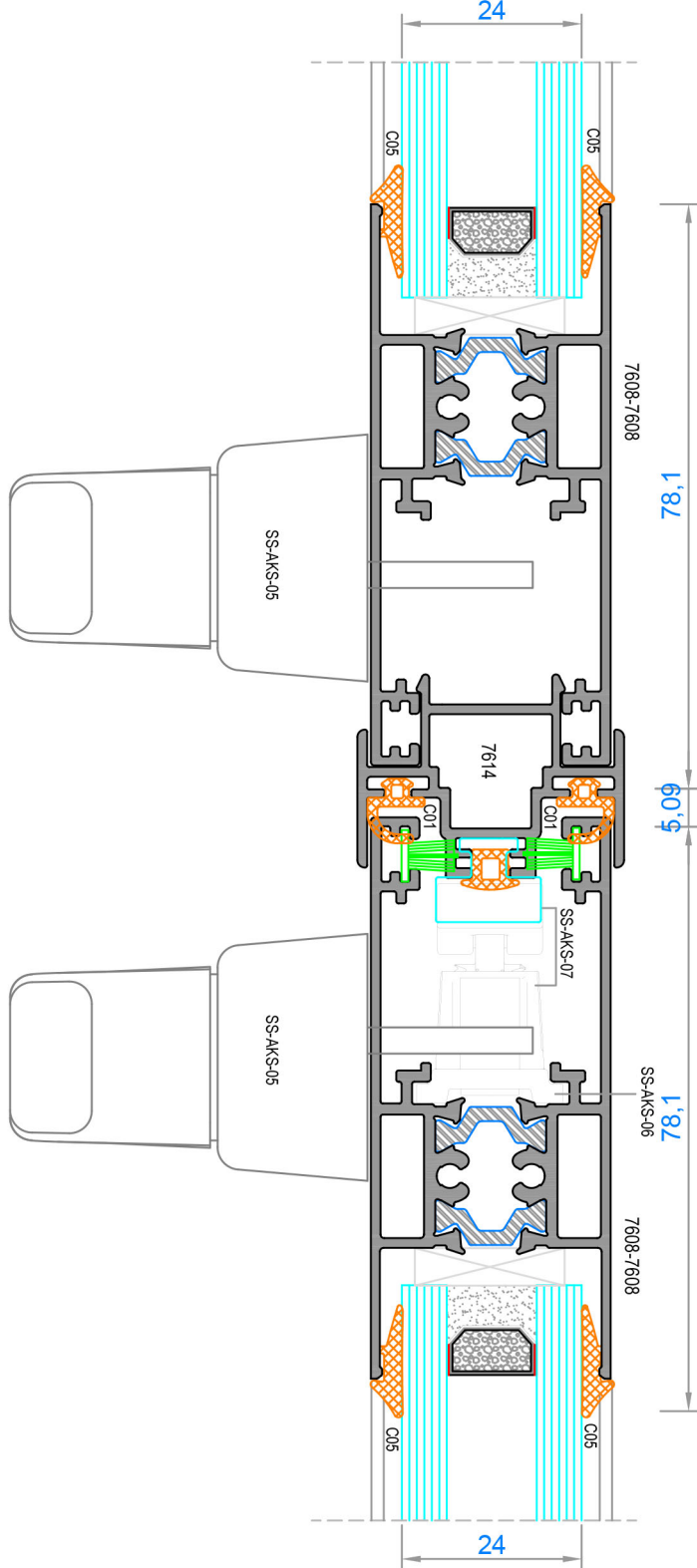
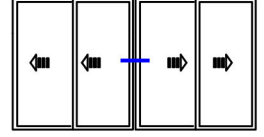

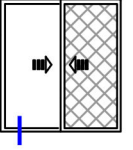
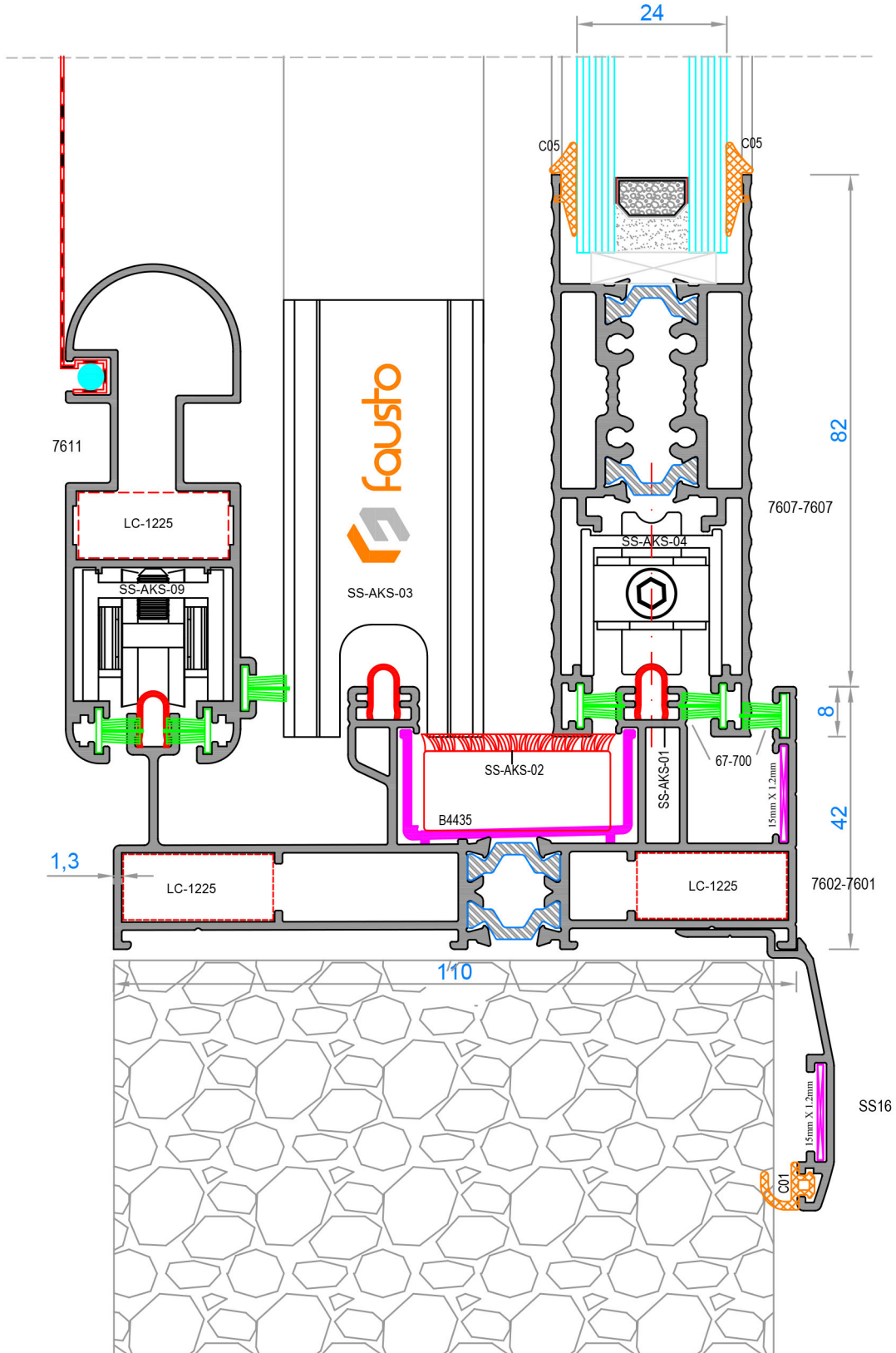

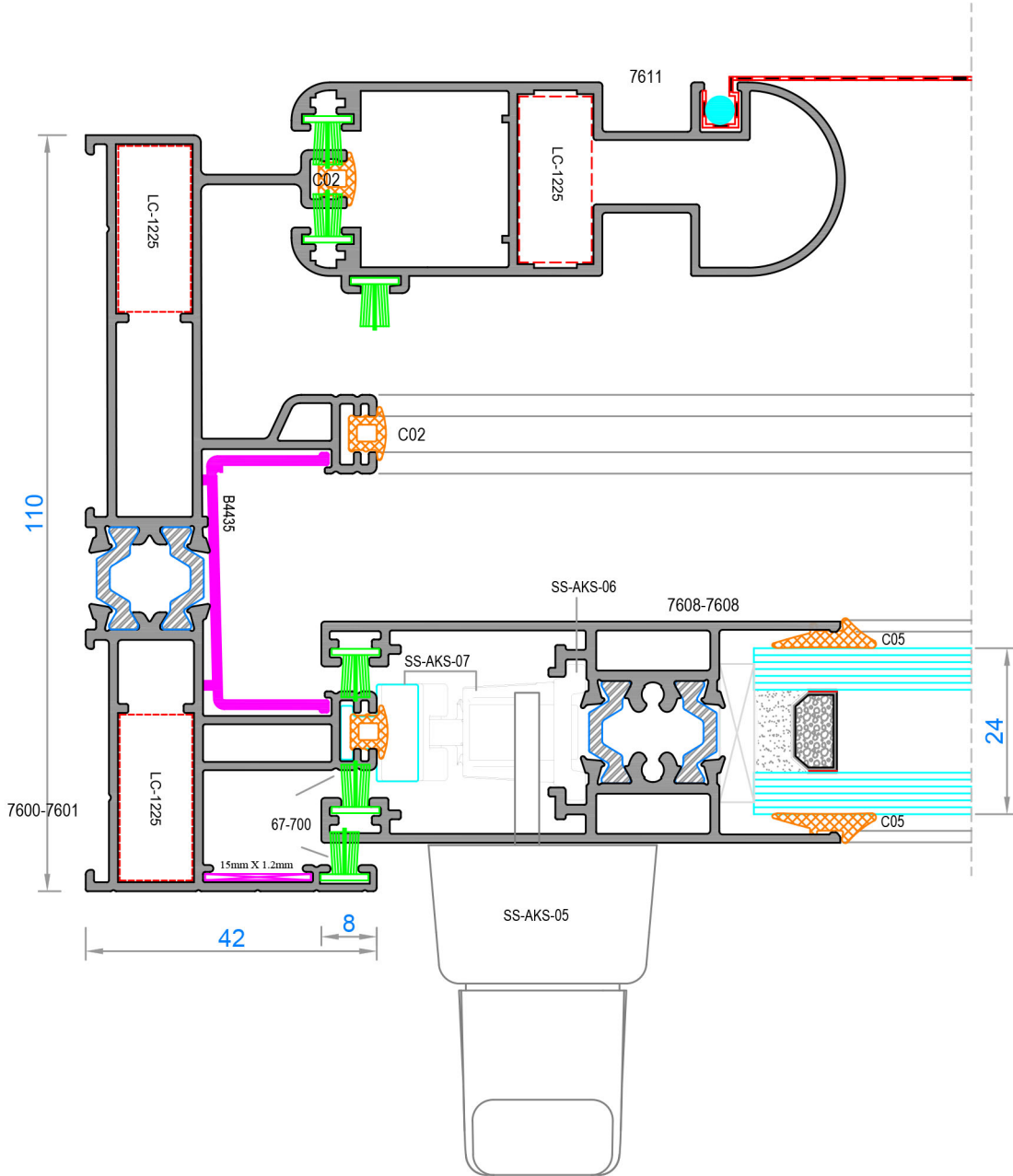
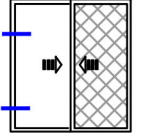

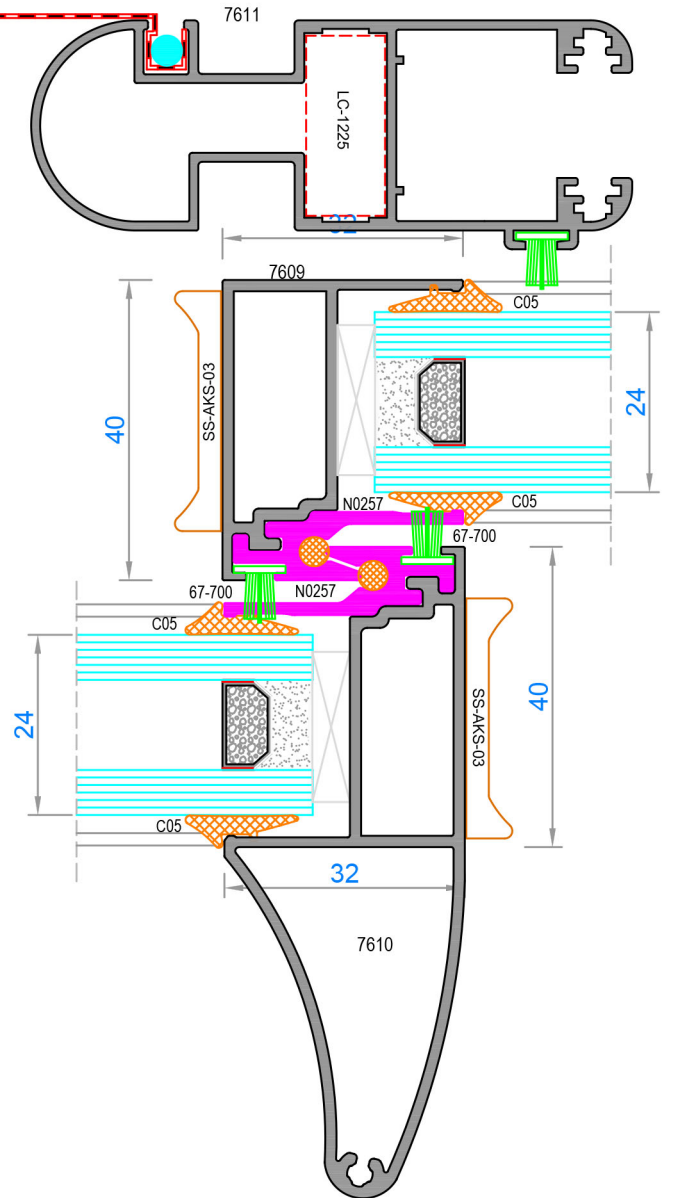
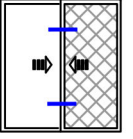
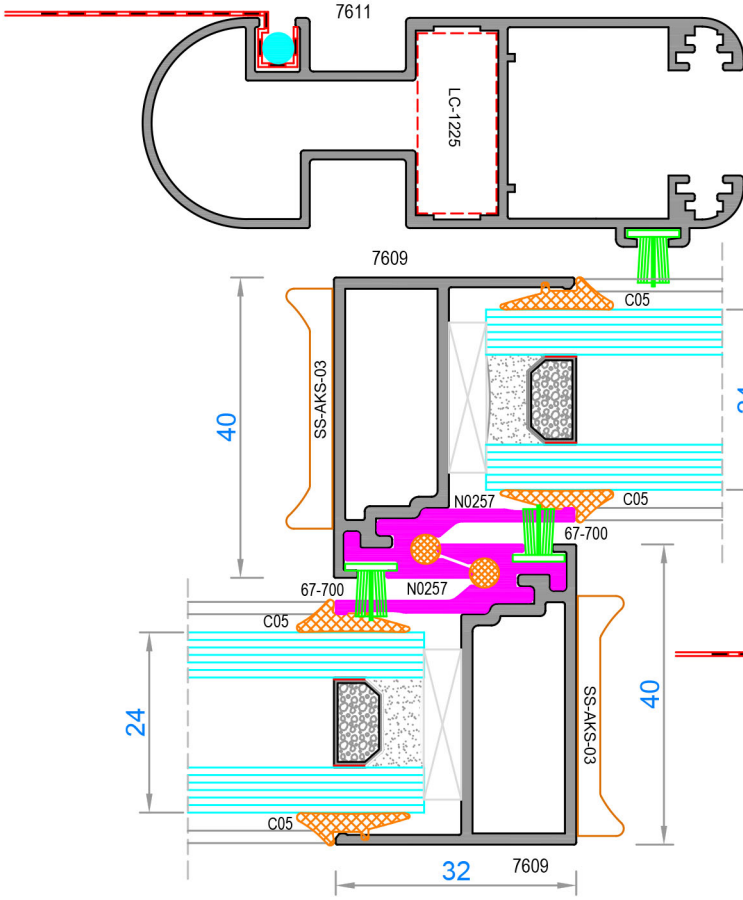



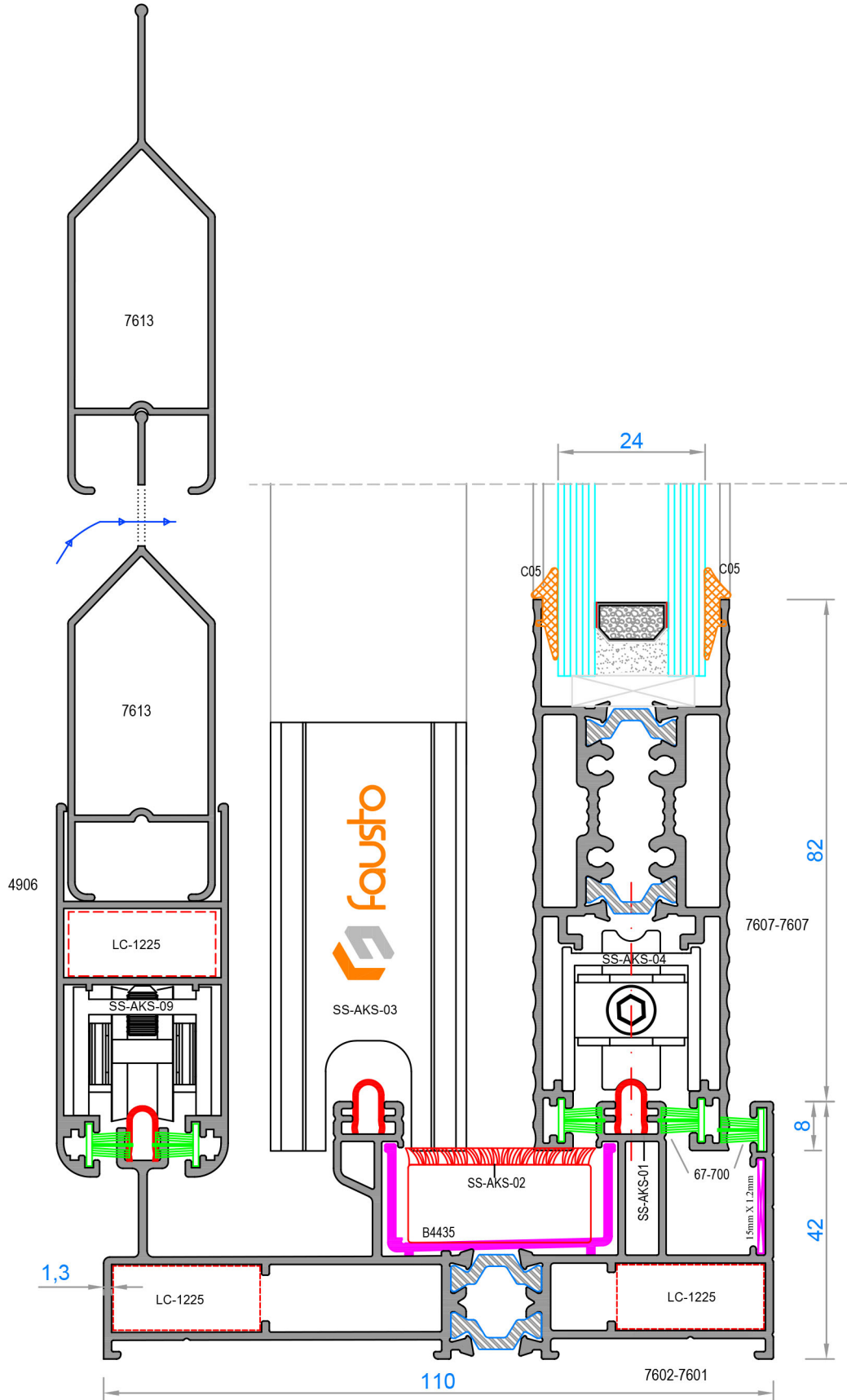
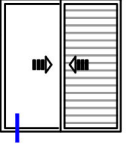

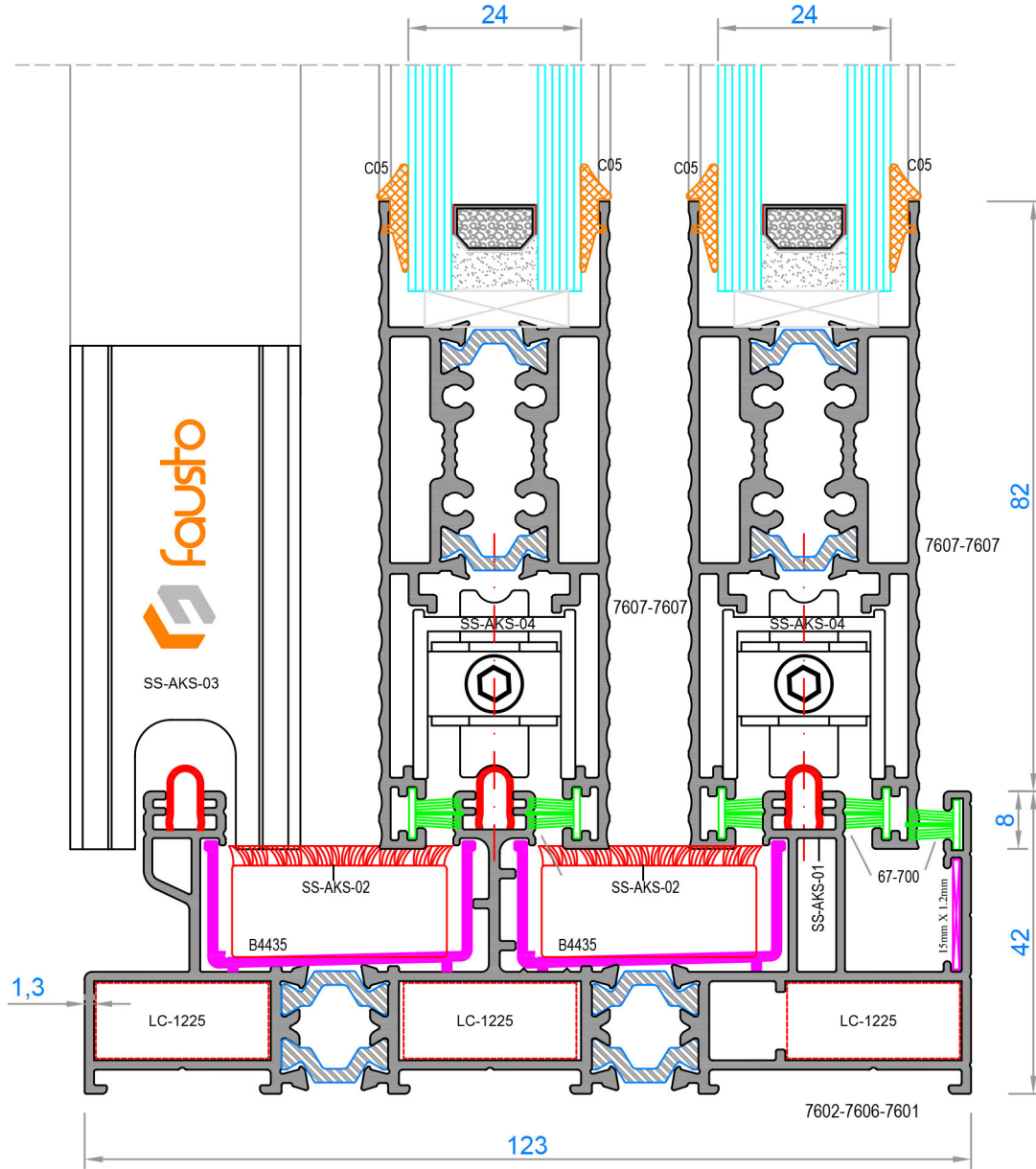
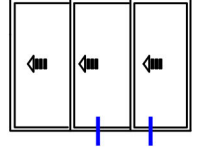

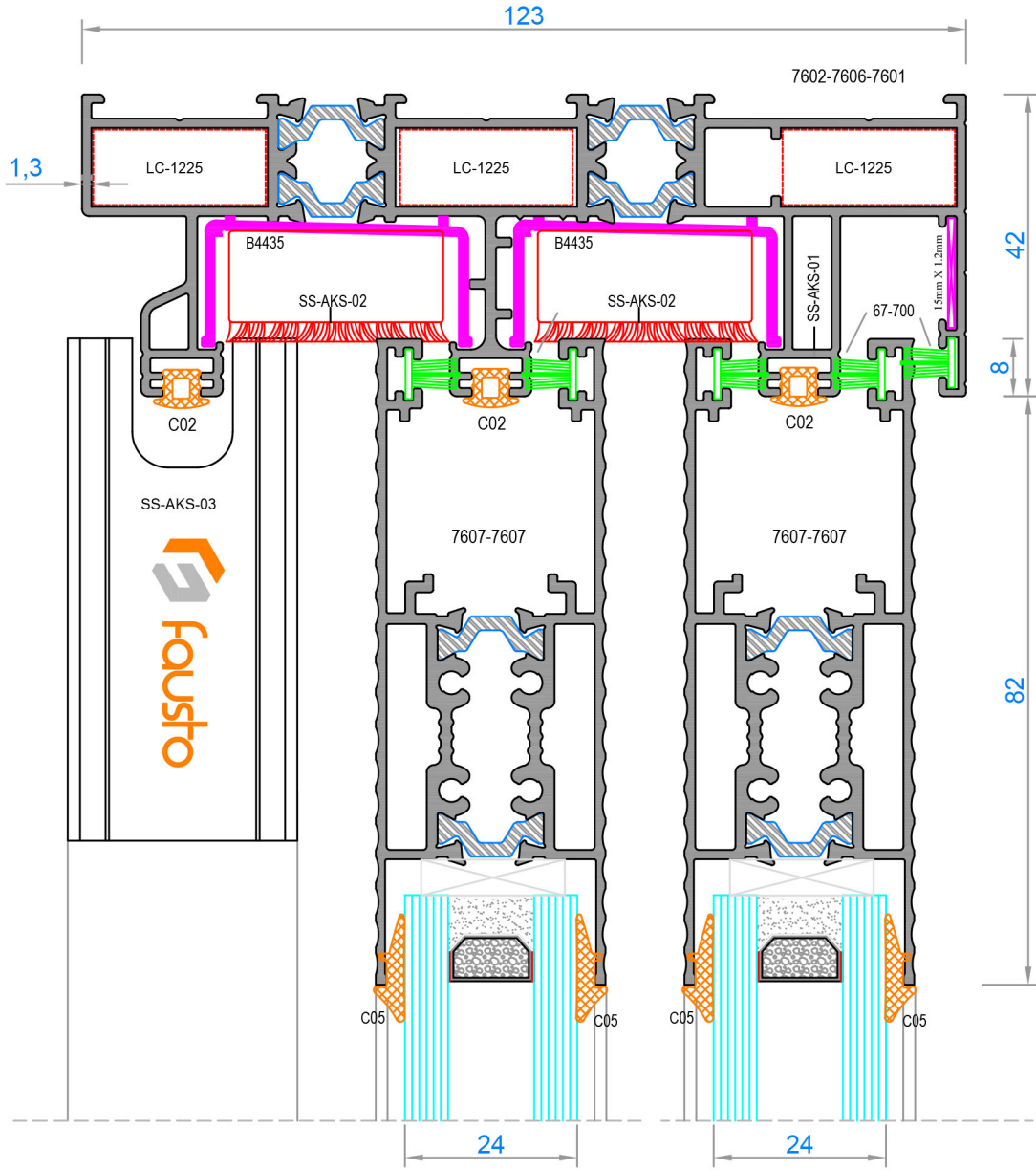
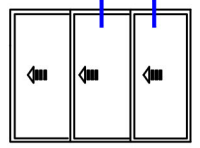

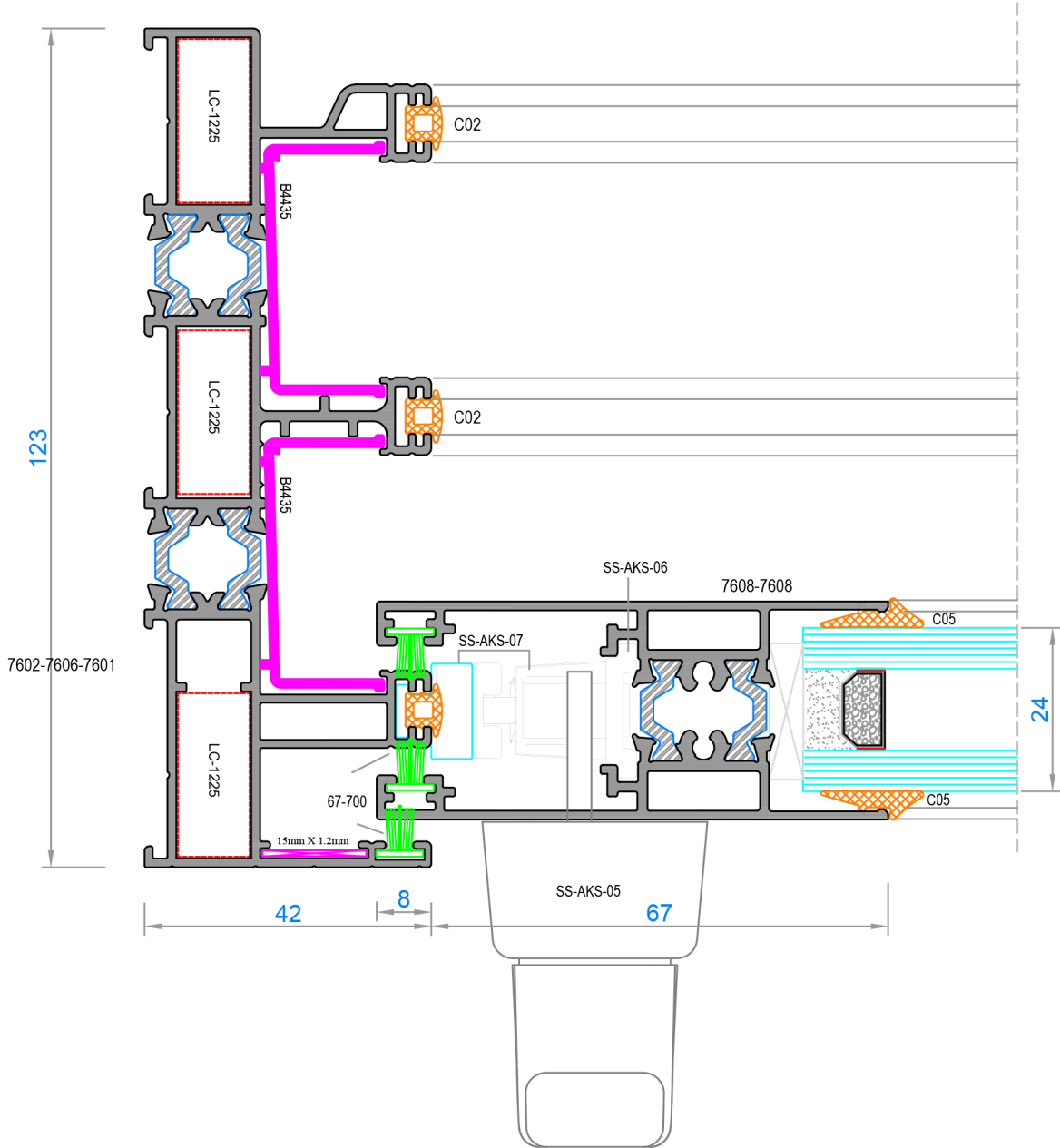
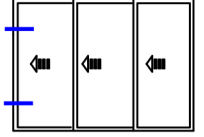

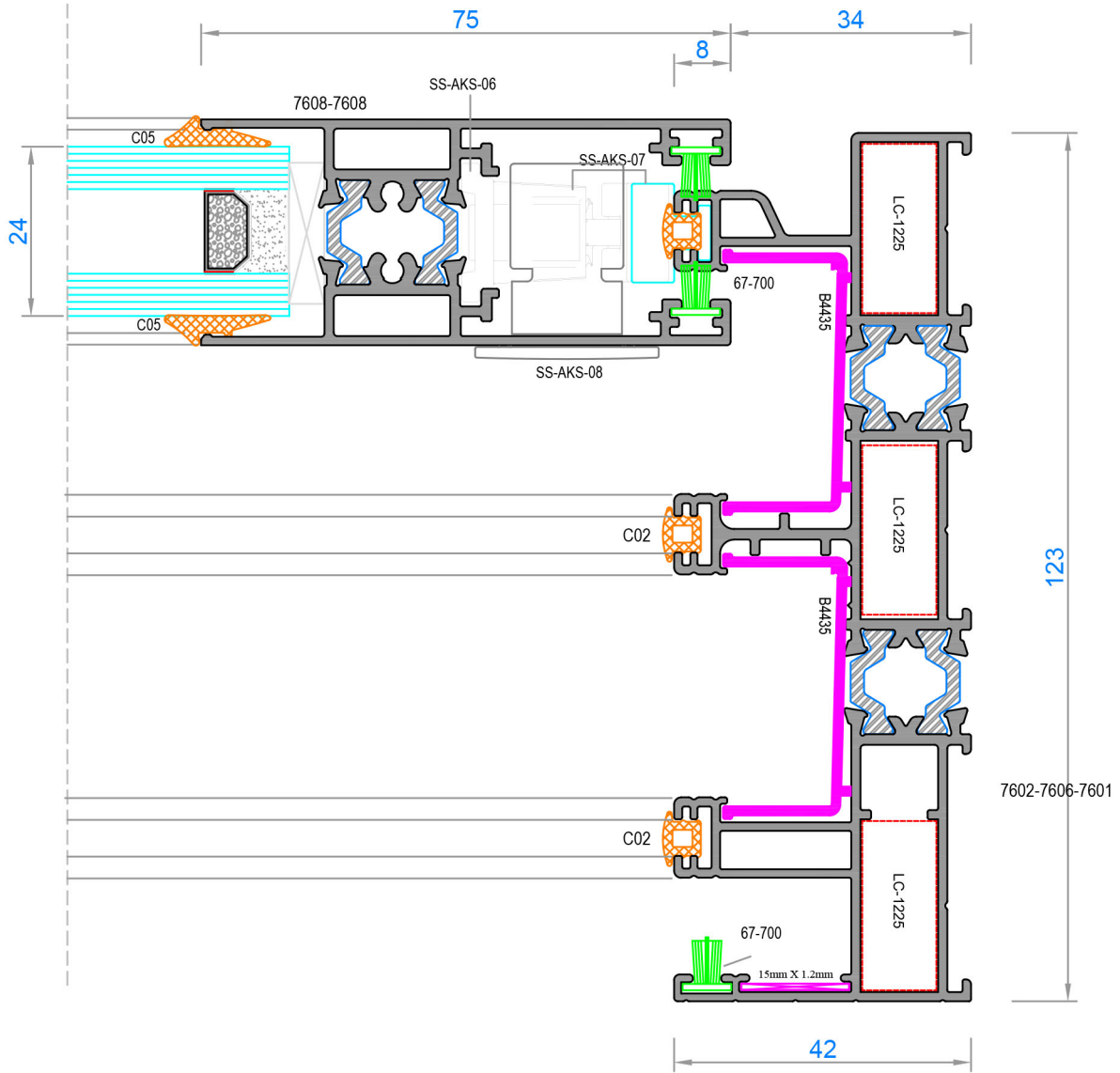
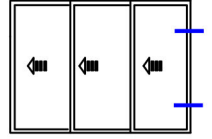

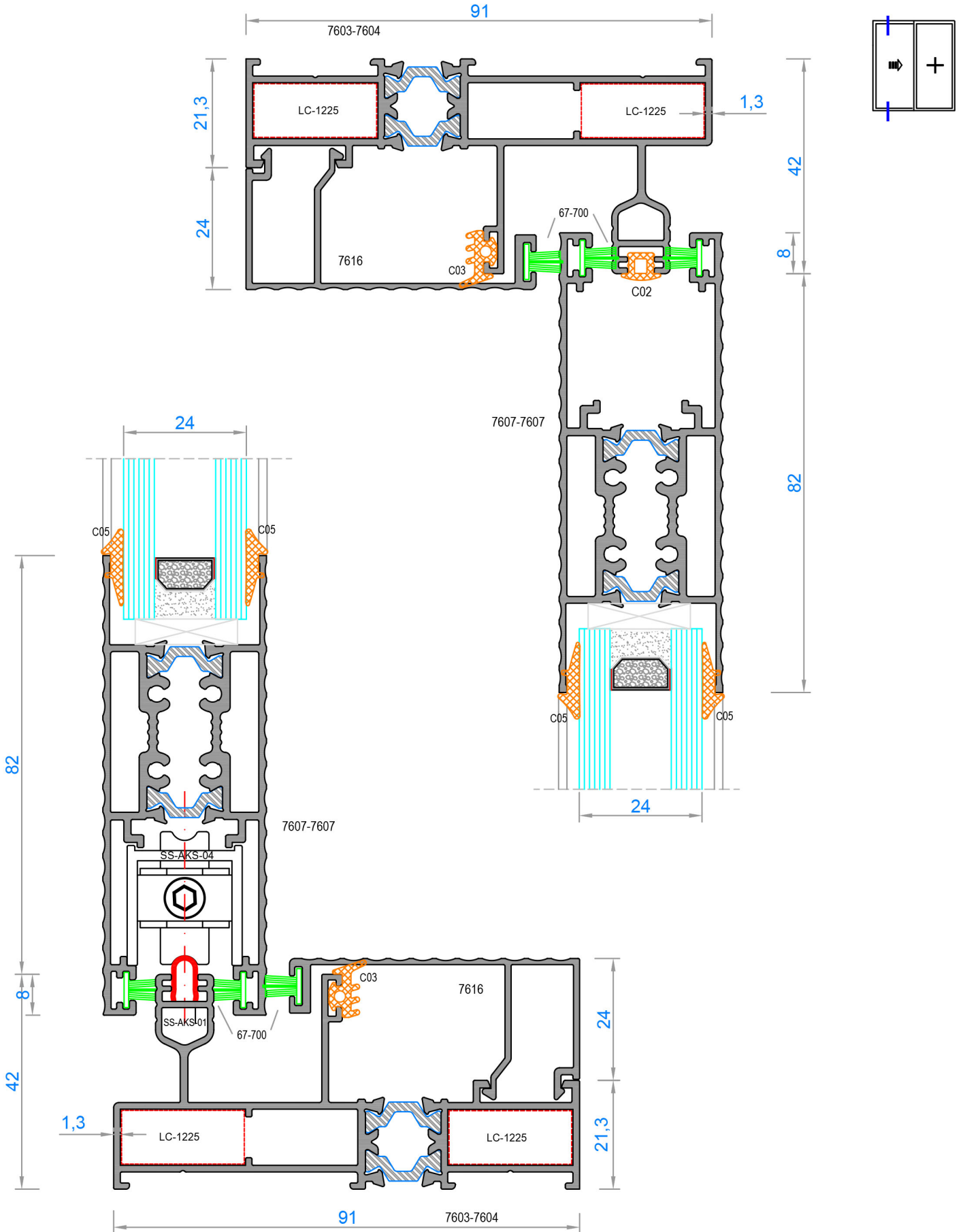

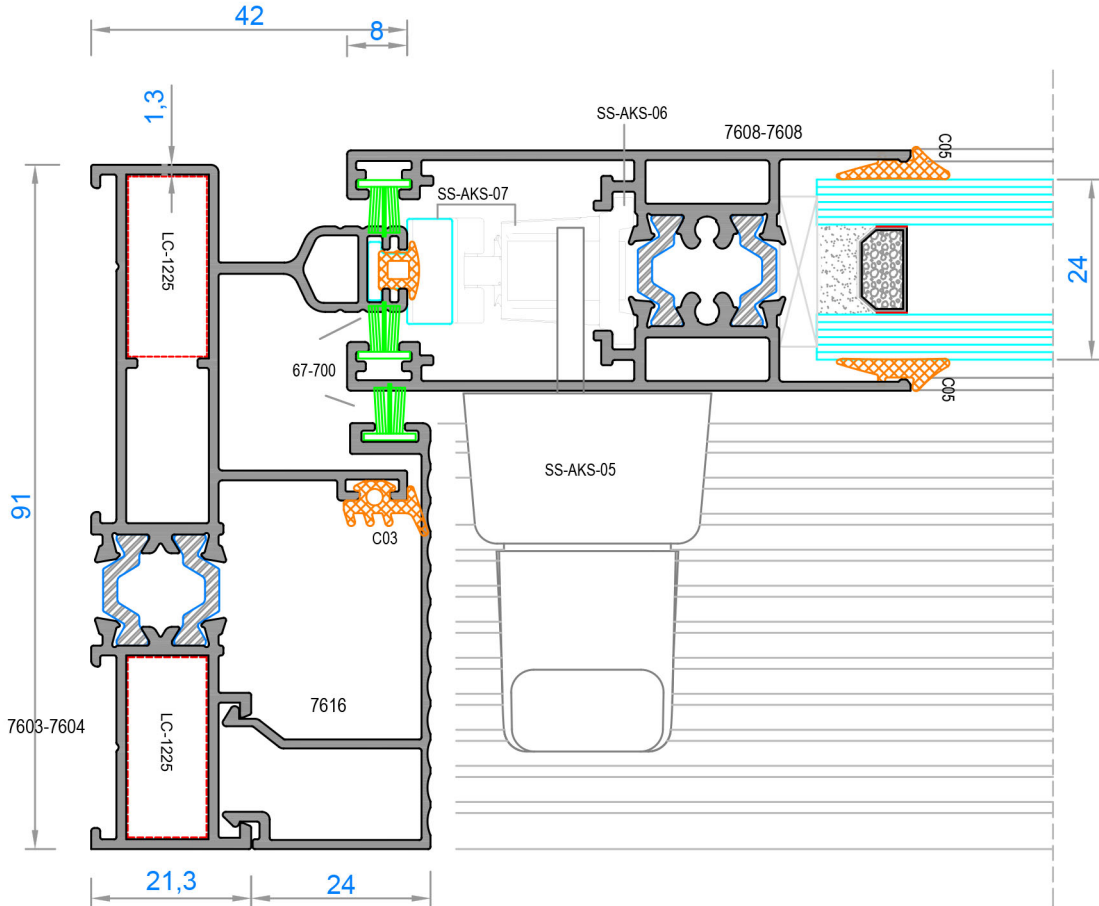
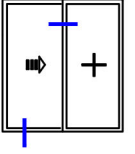
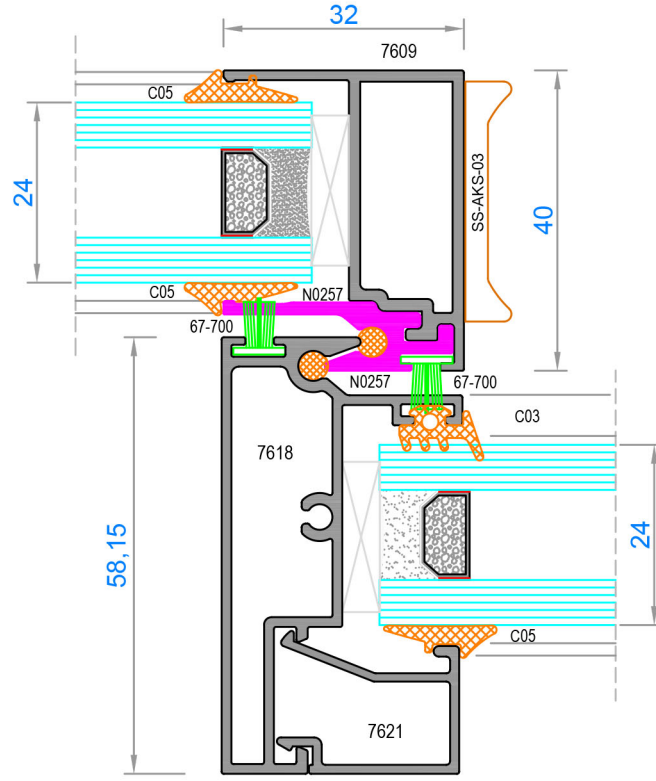

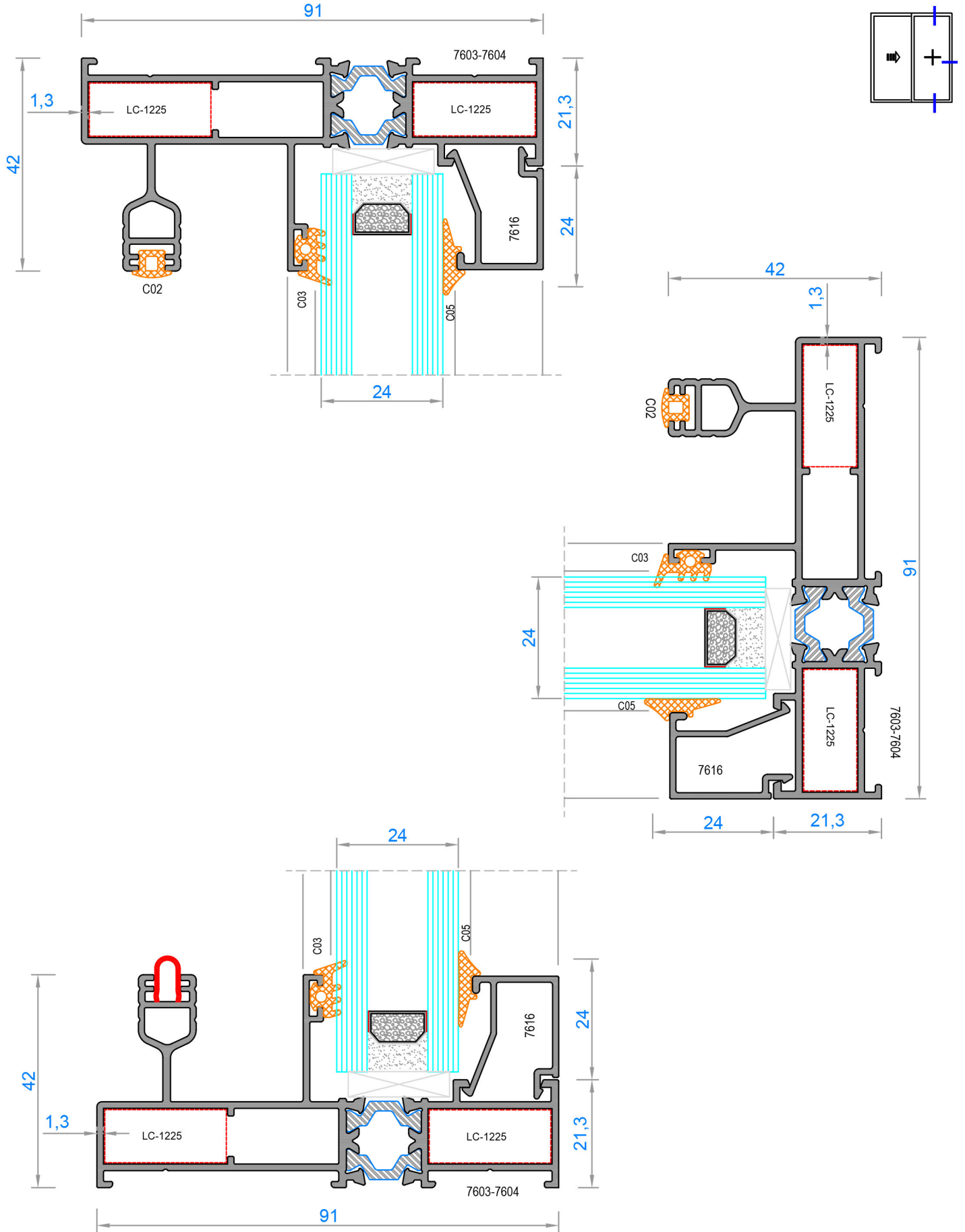



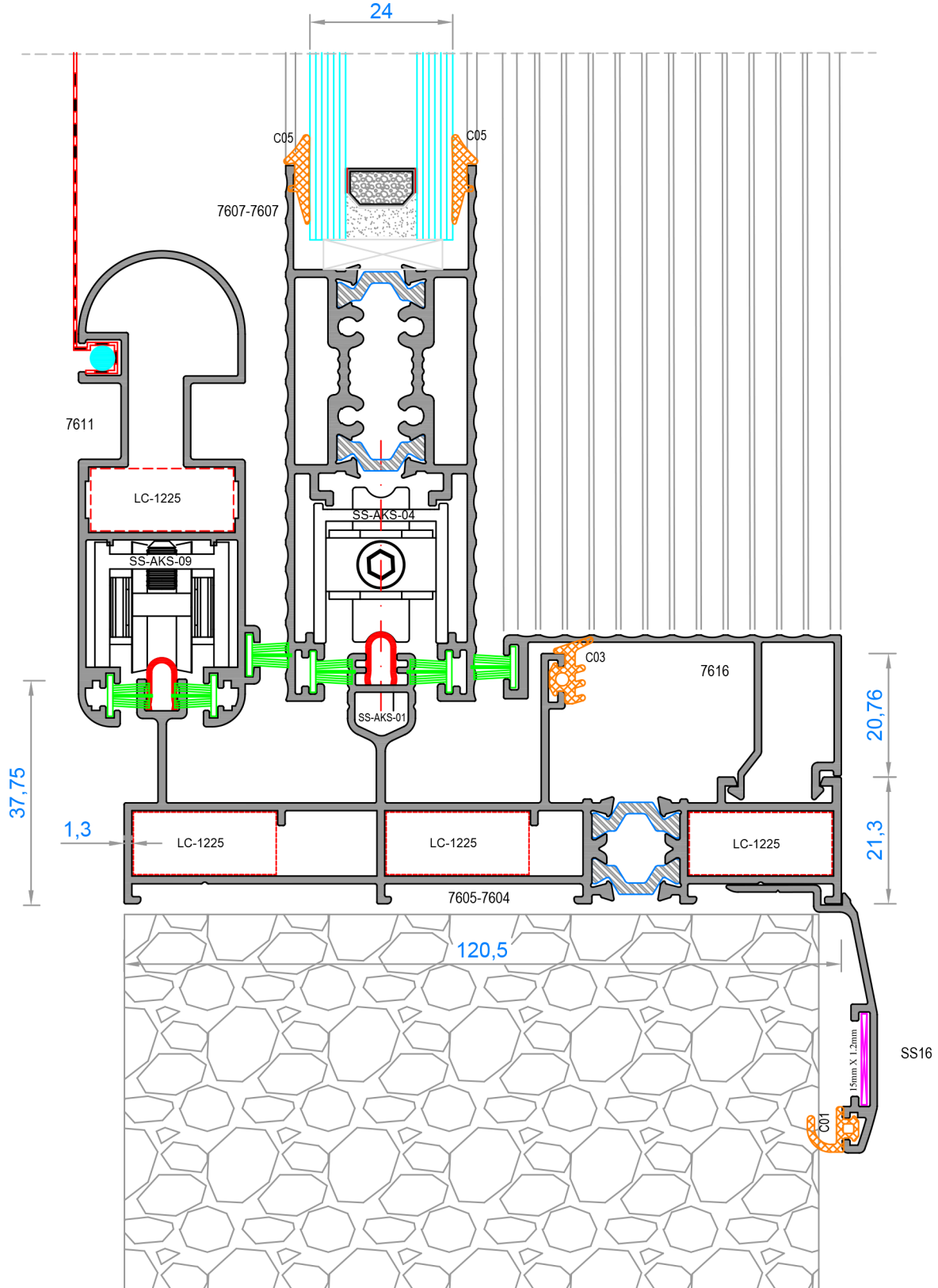
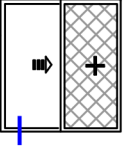

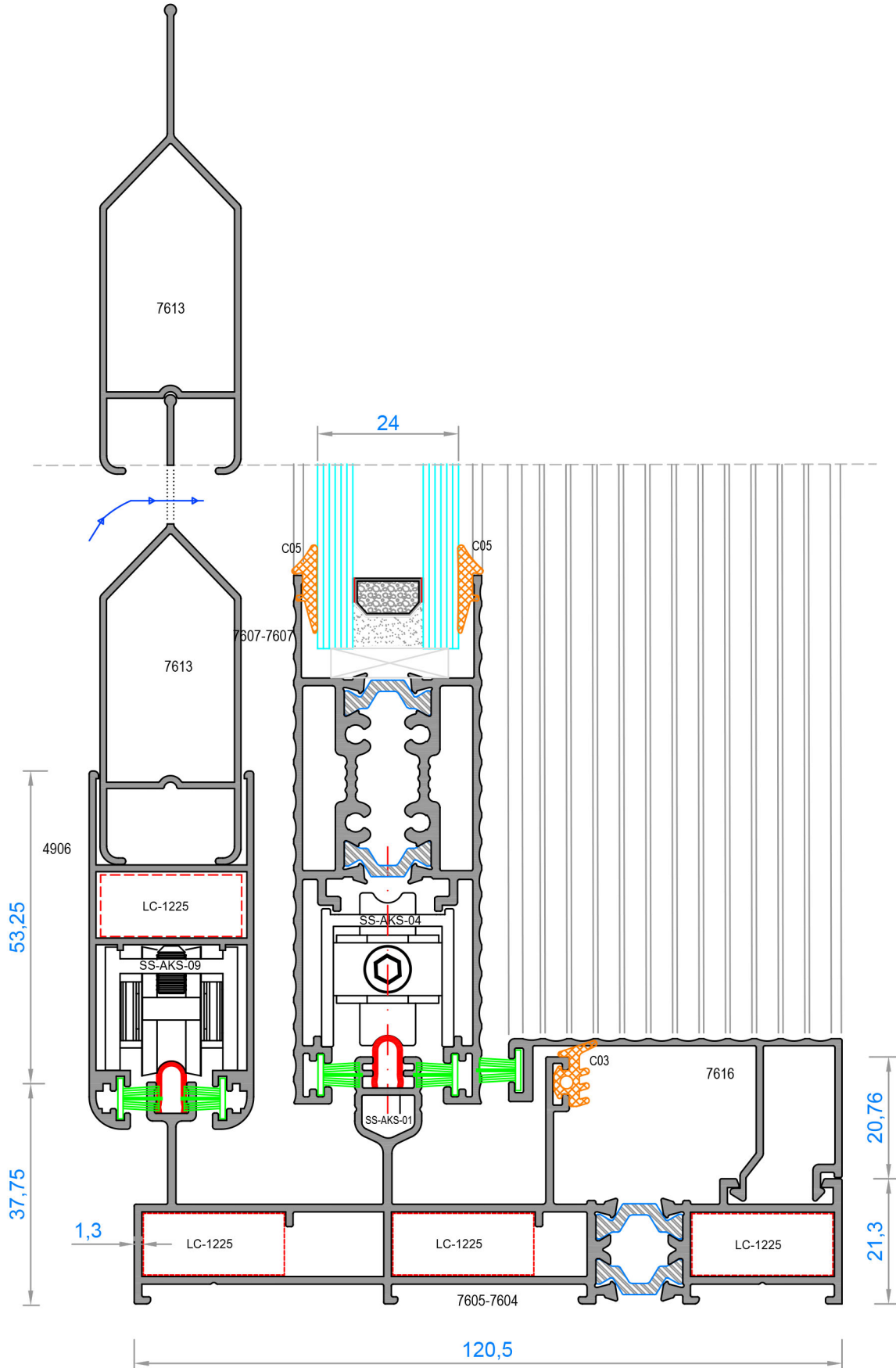
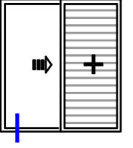

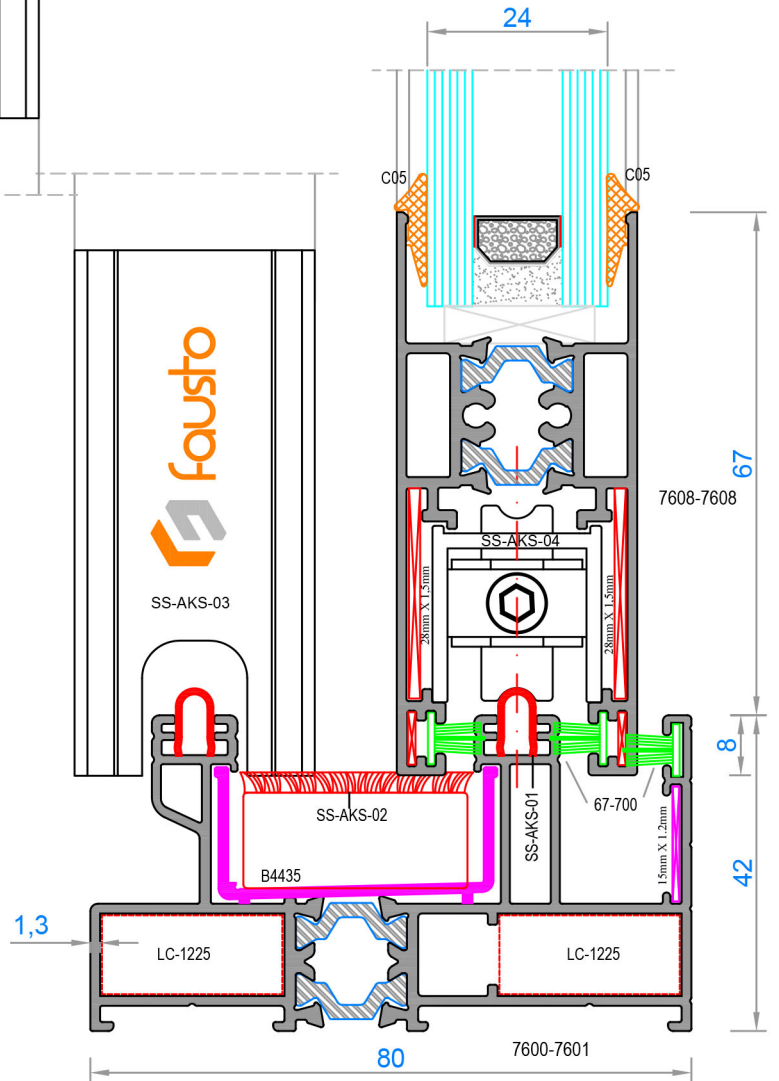
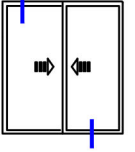
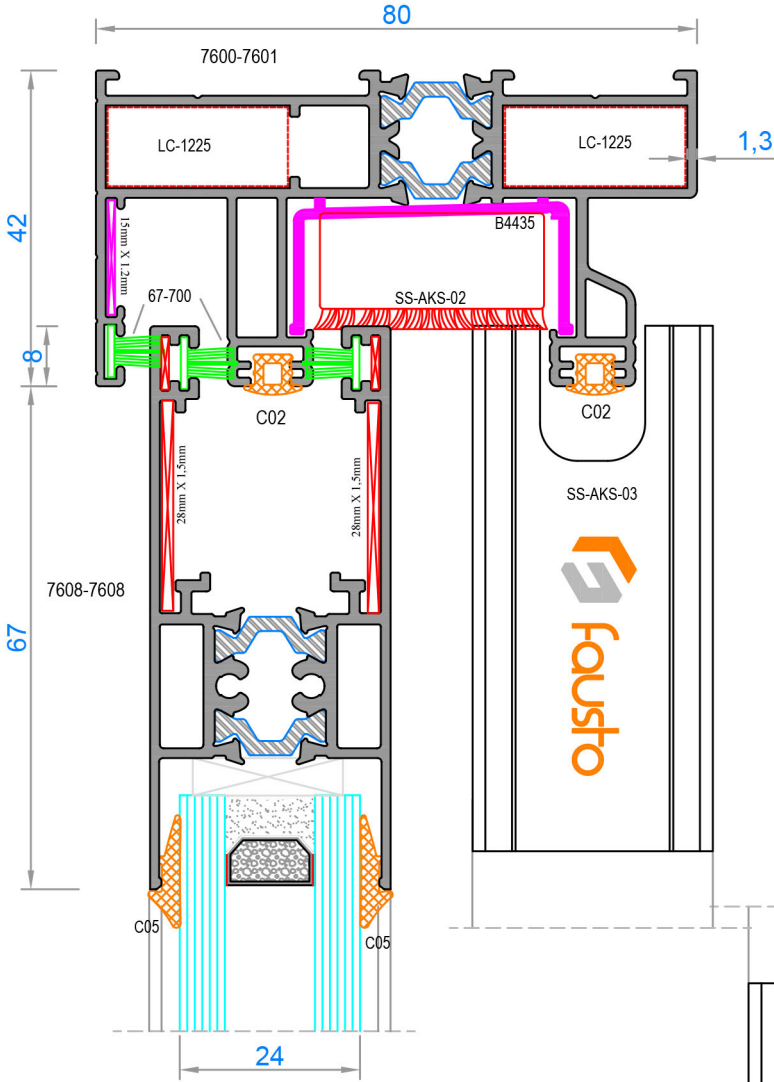

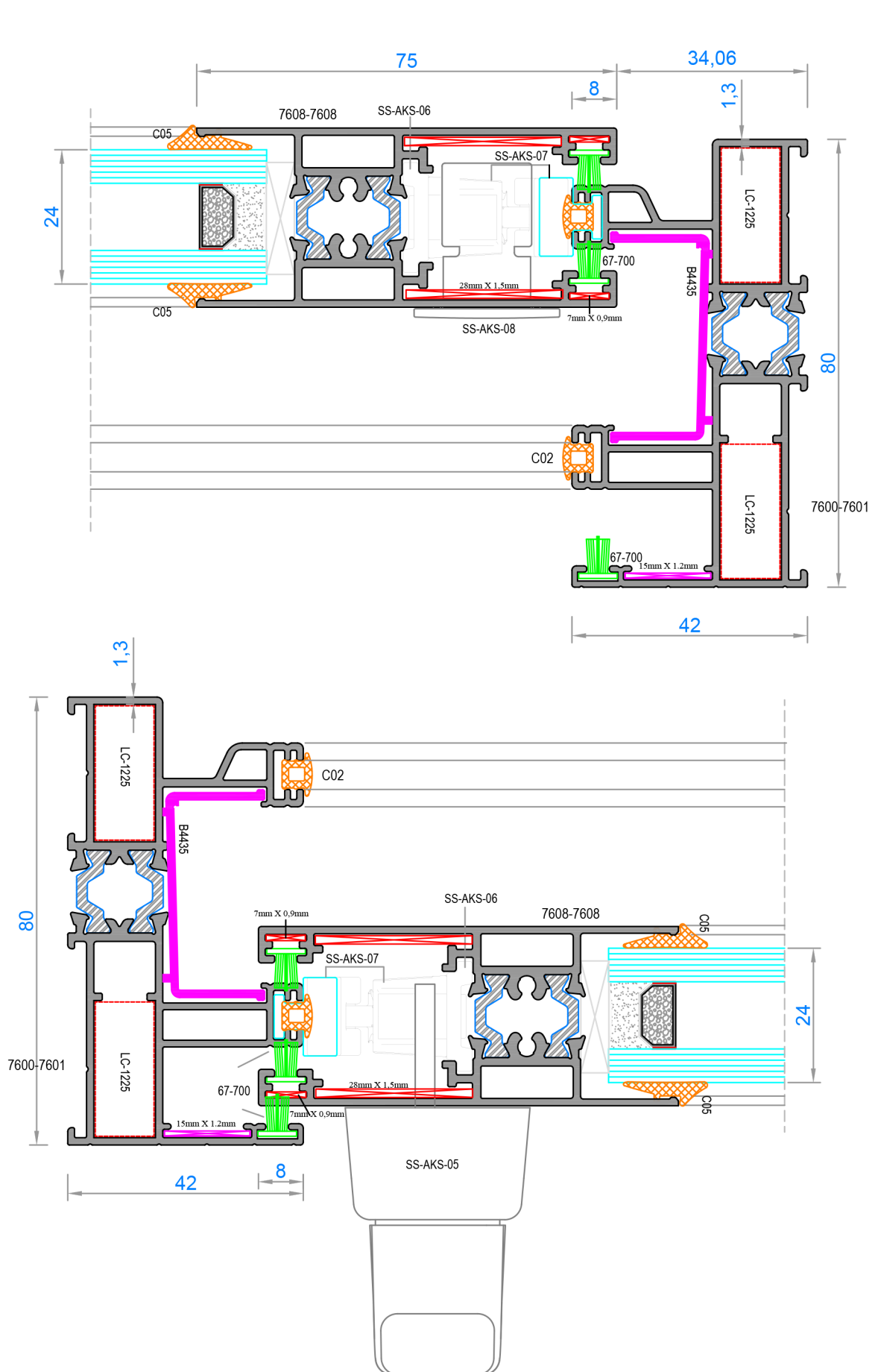

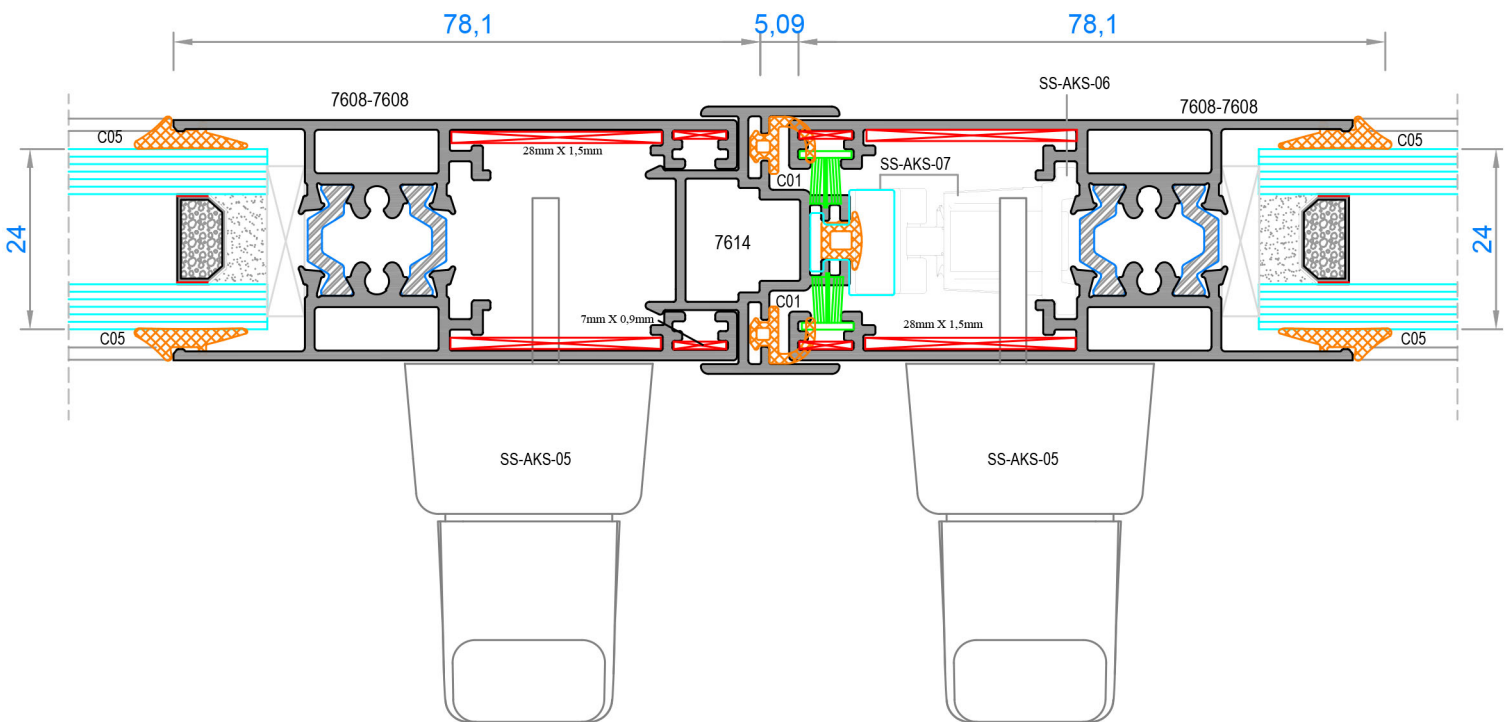
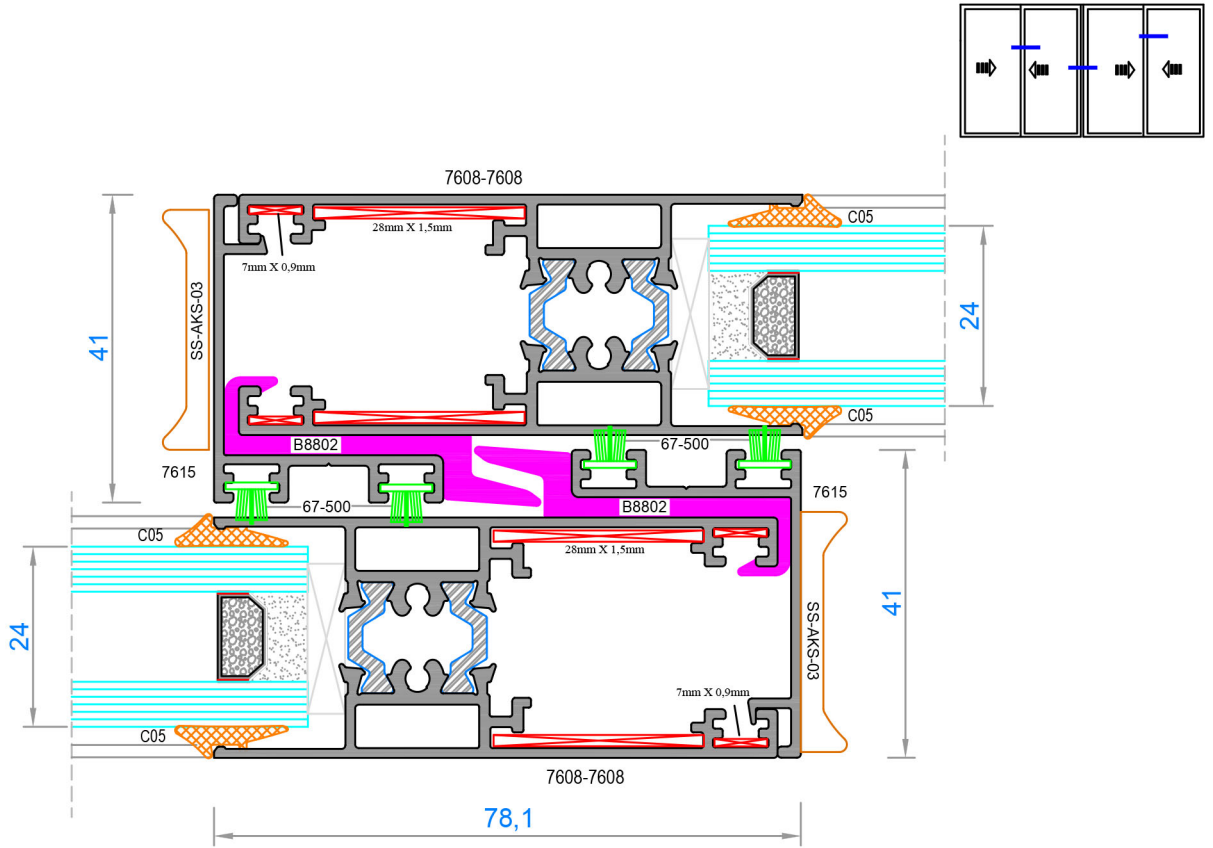

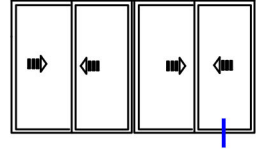
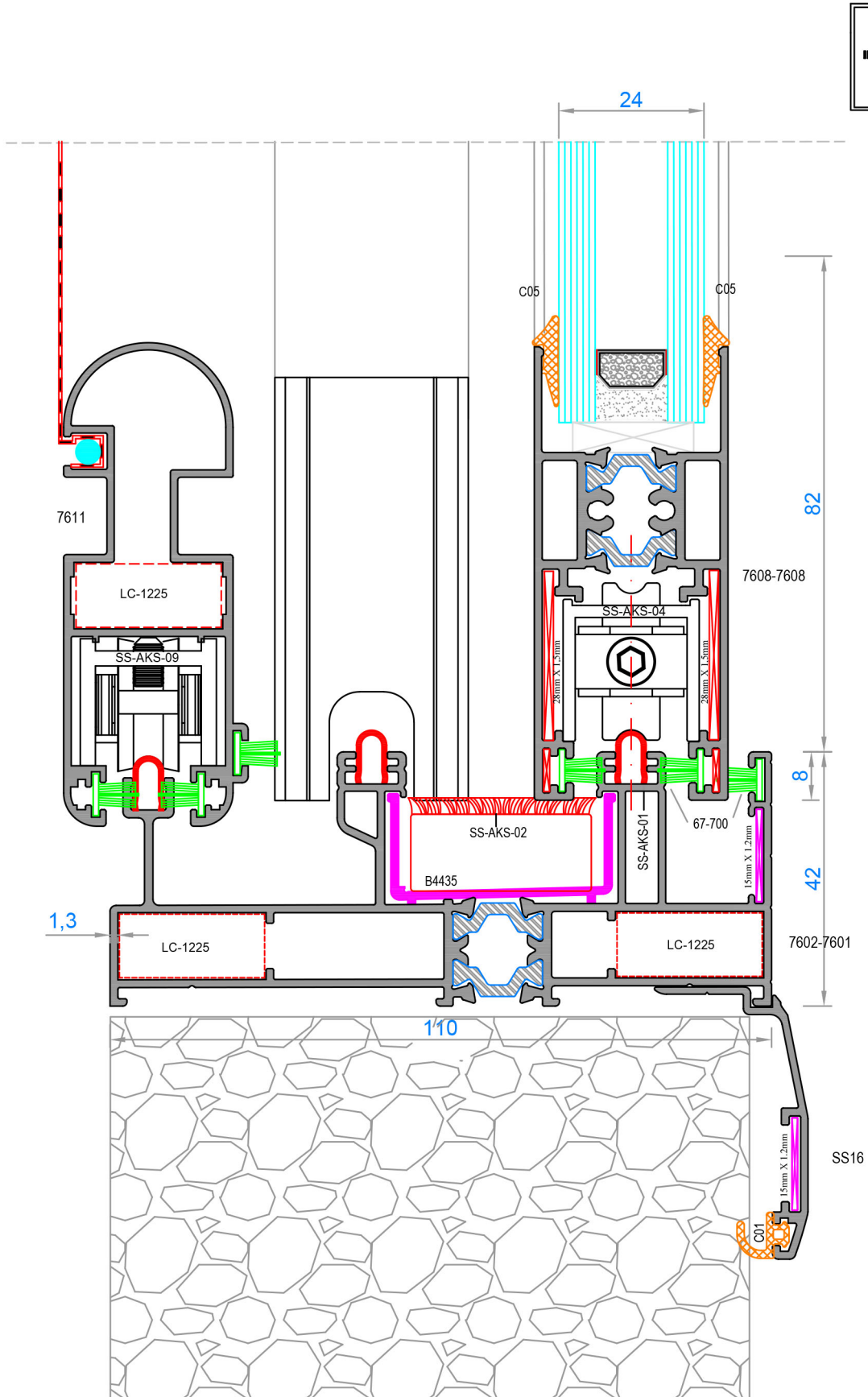

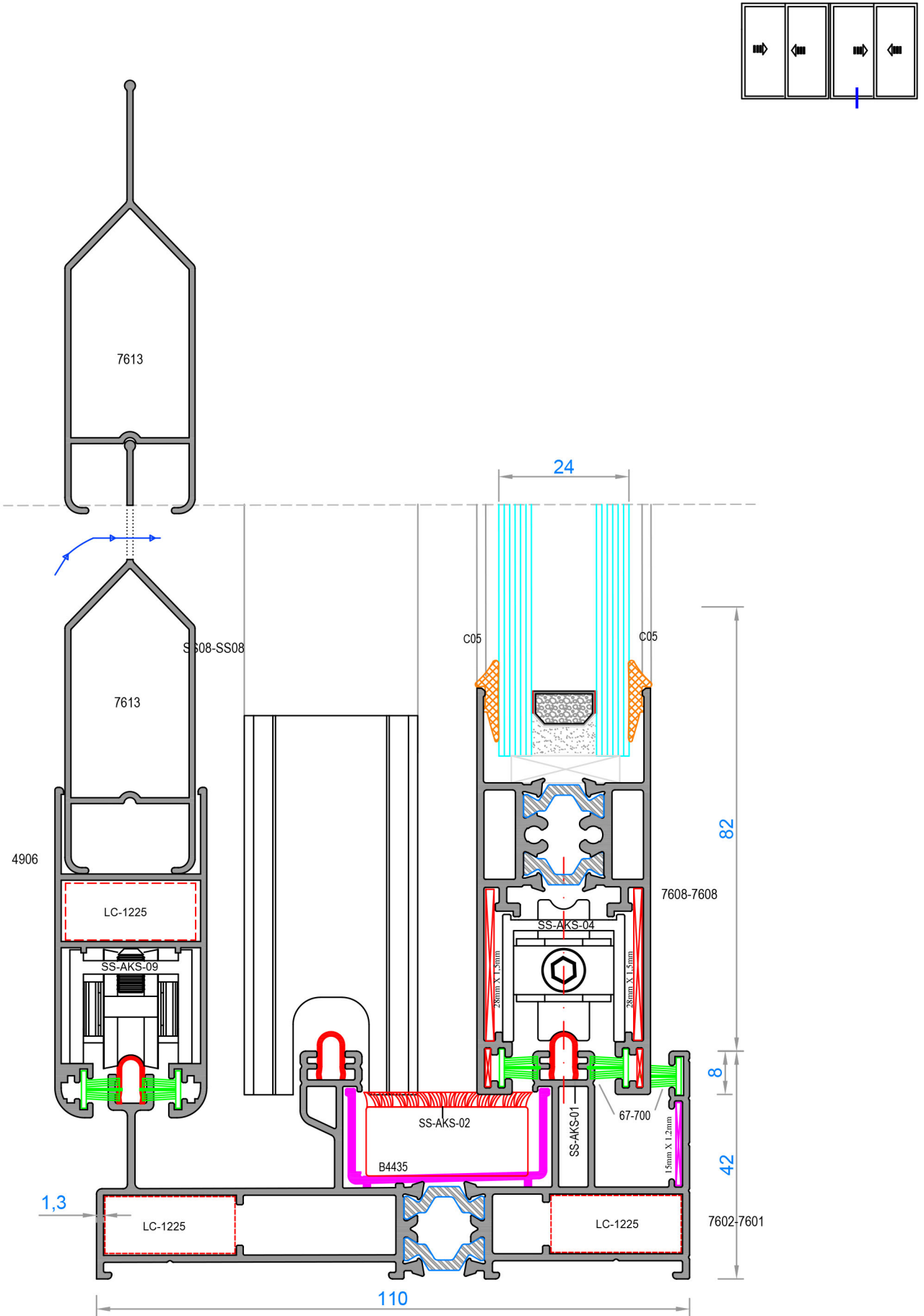

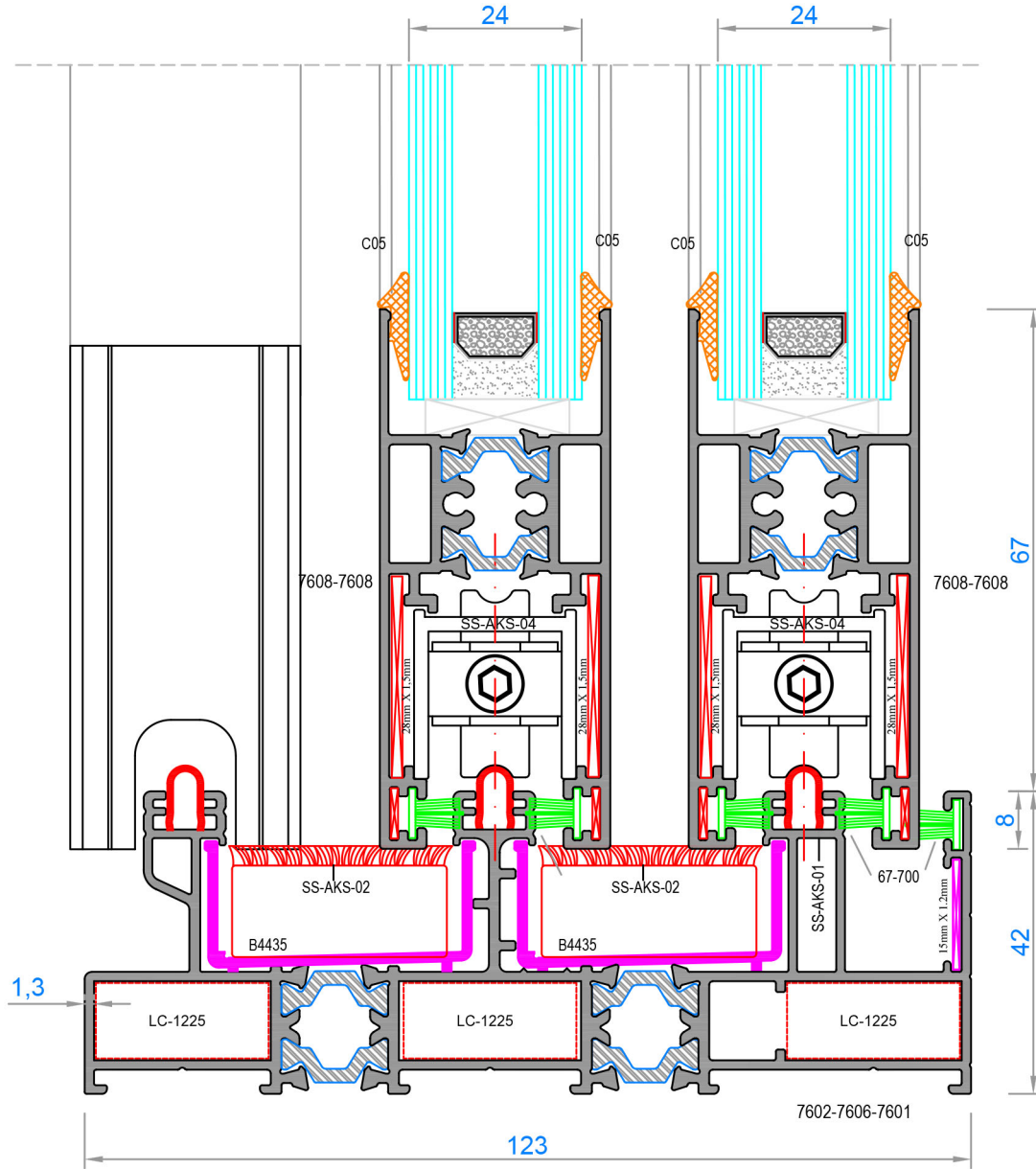
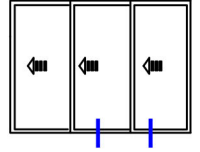



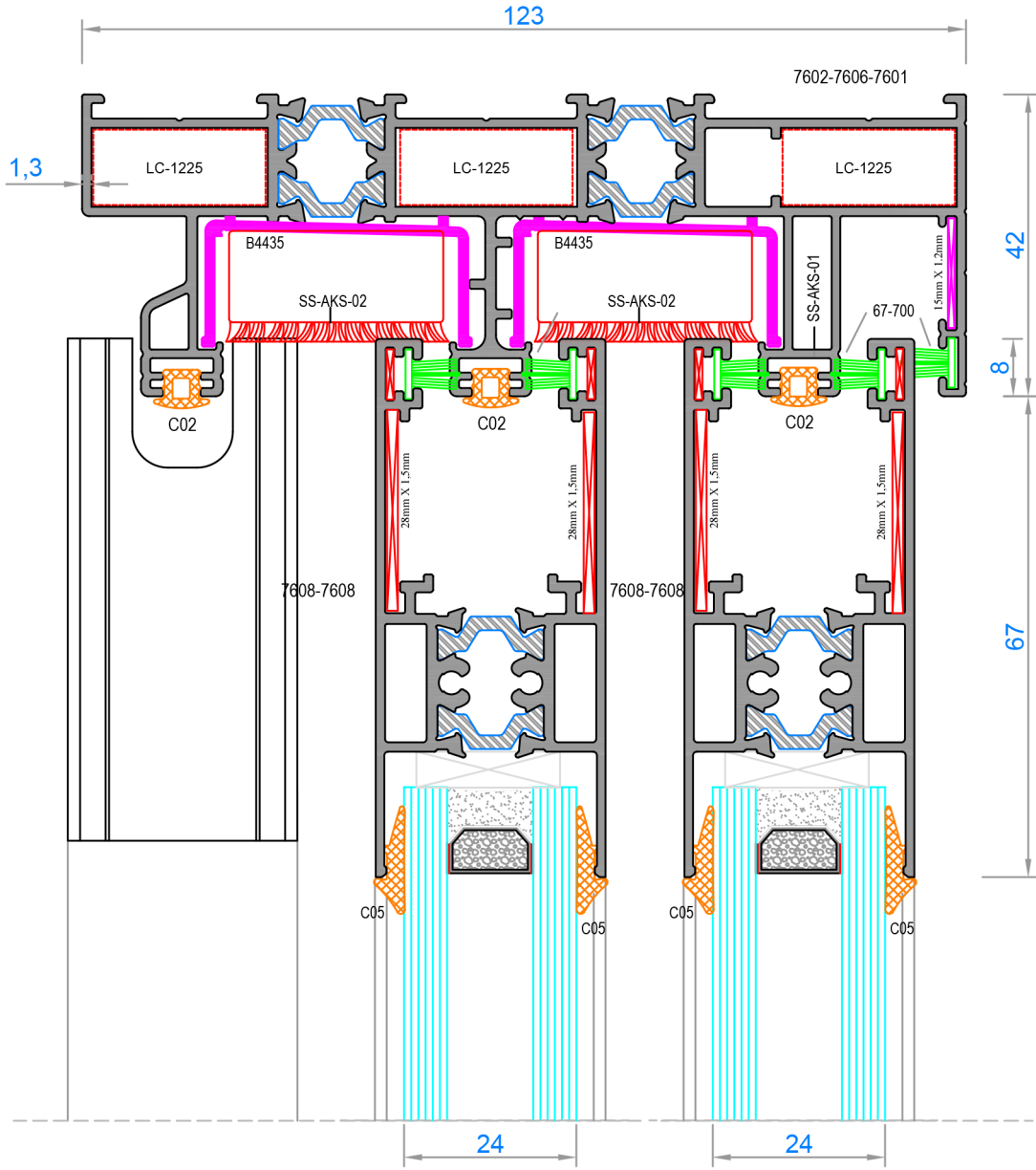
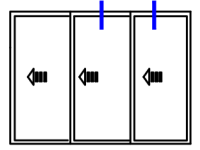

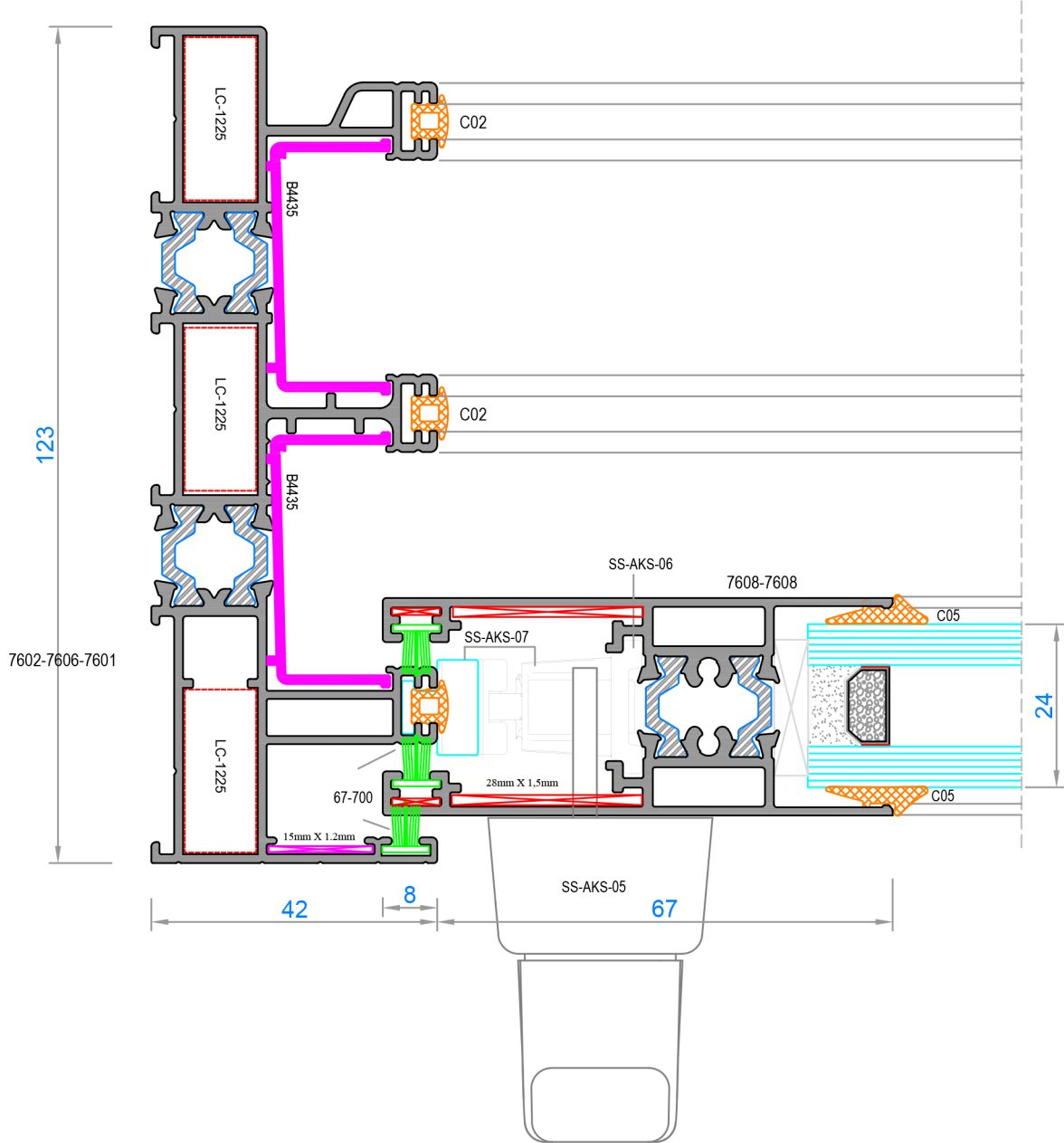
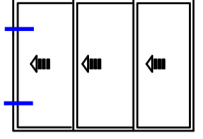

AÇILIM TİPLERİ - OPENING TYPES

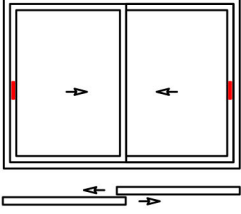

2 HAREKETLİ KANAT  
2 SLIDING SASH

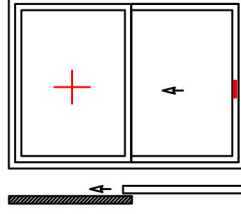

1 HAREKETLİ 1 SABİT KANAT  
1 SLIDING 1 FIX SASH

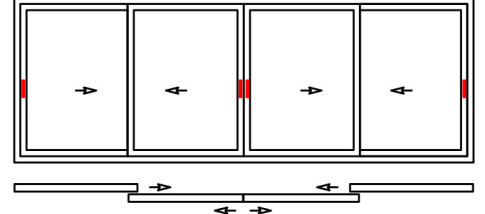

4 HAREKETLİ KANAT  
4 SLIDING SASH

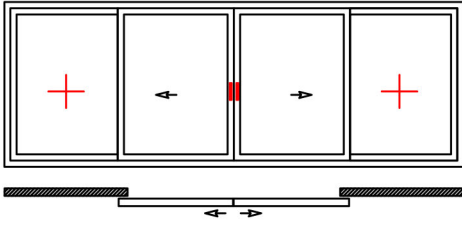

2 HAREKETLİ 2 SABİT KANAT  
2 SLIDING 2 FIX SASH

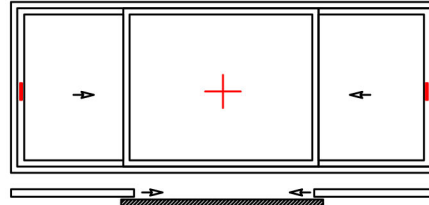

2 HAREKETLİ 1 SABİT KANAT  
2 SLIDING 1 FIX SASH

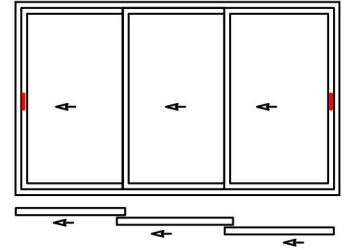

3 HAREKETLİ KANAT  
3 SLIDING SASH

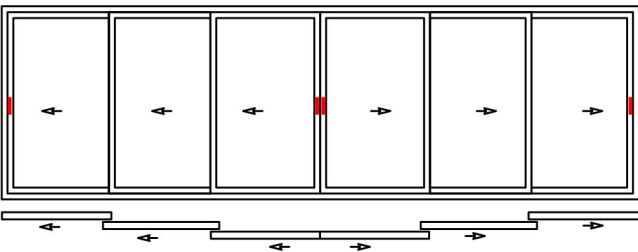

6 HAREKETLİ KANAT  
6 SLIDING SASH

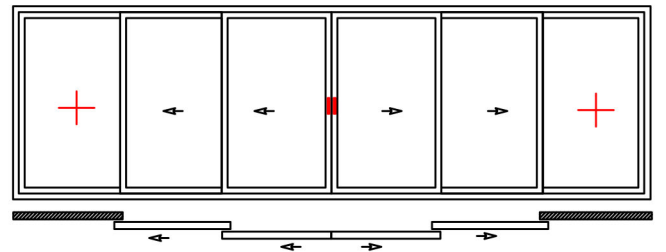

4 HAREKETLİ 2 SABİT KANAT  
4 SLIDING 2 FIX SASH

STATİK DİYAGRAMLAR - STATIC DIAGRAMS

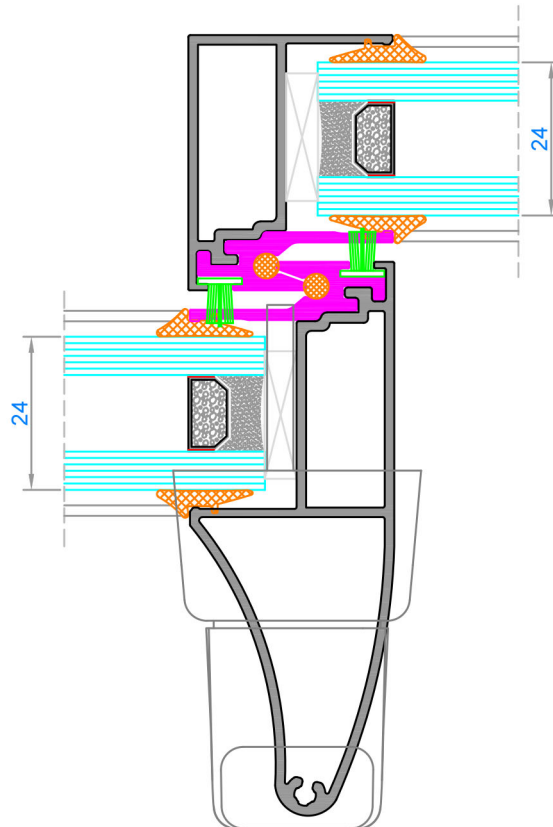
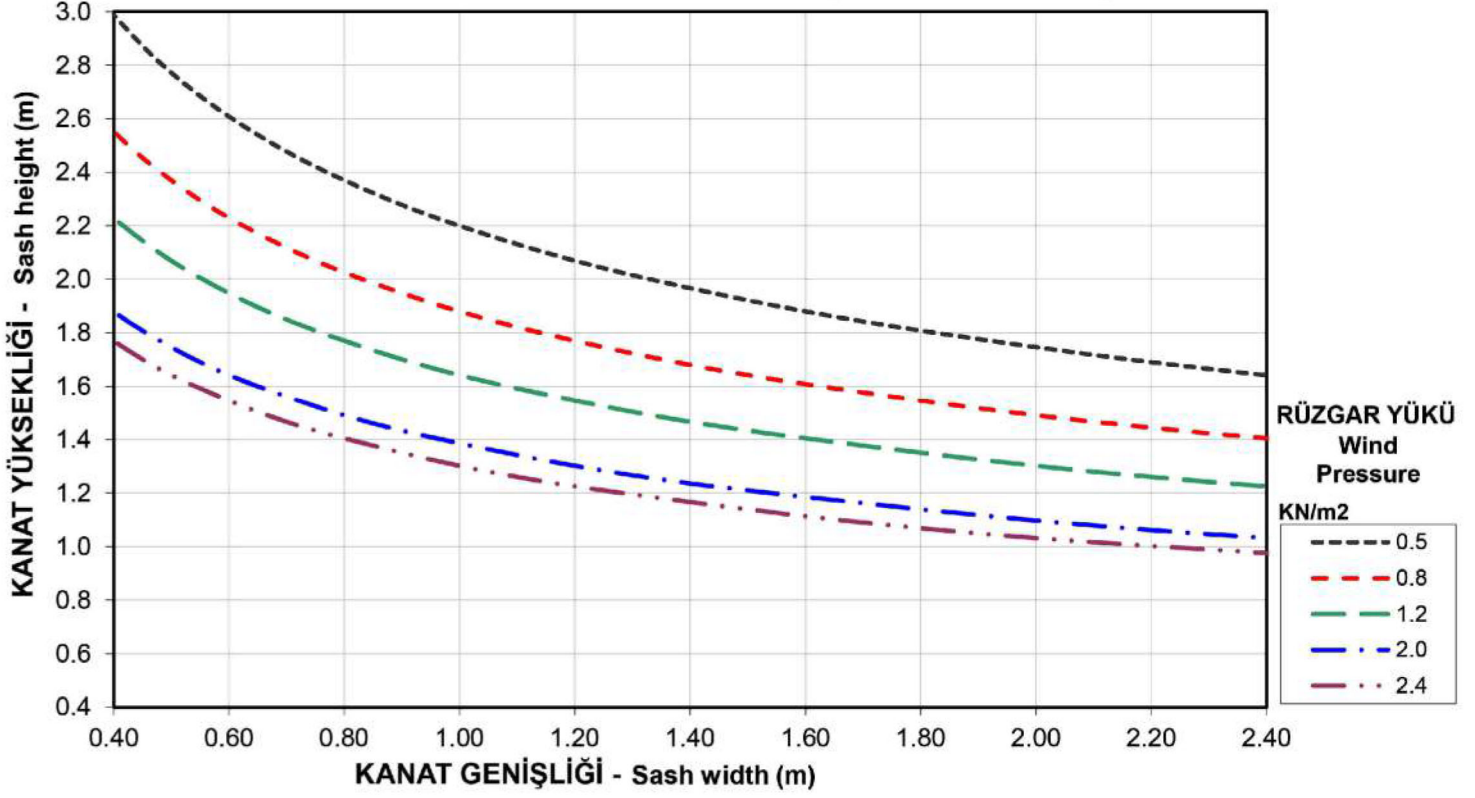

KASA MONTAJ ŞEMASI - FRAME ASSEMBLY SCHEME

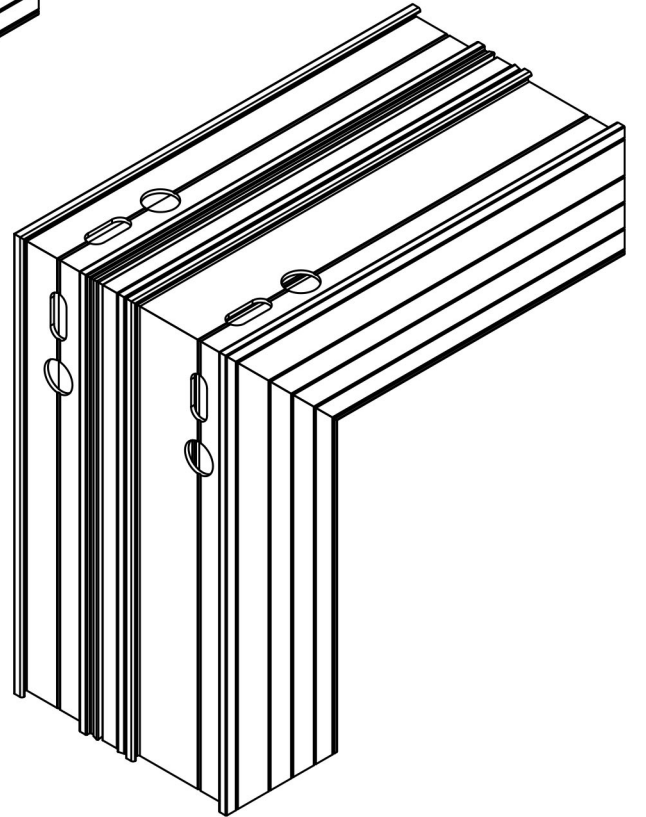
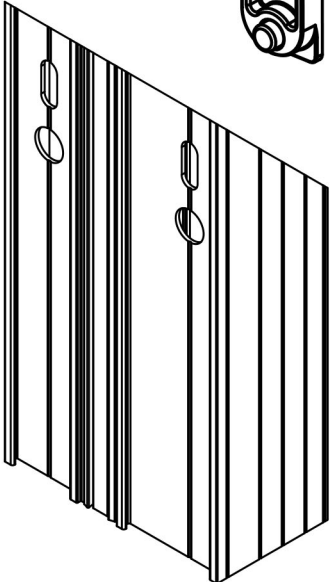
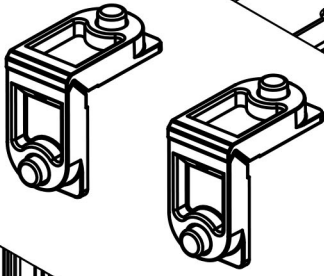
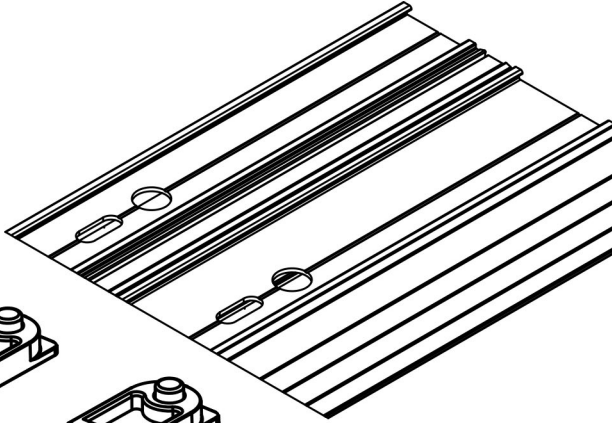
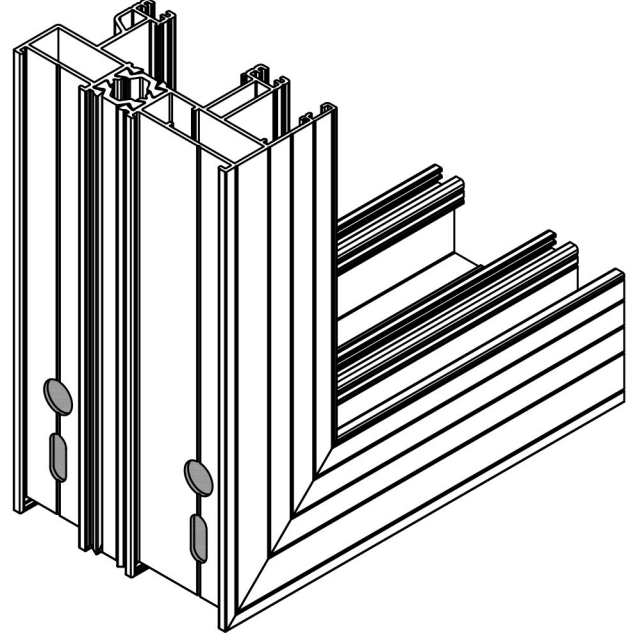
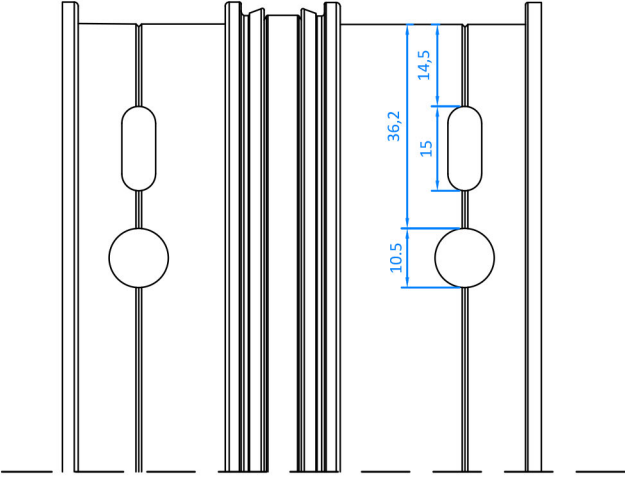

SU TAHLİYE MONTAJ ŞEMASI - WATER EMPTYING ASSEMBLY SCHEME

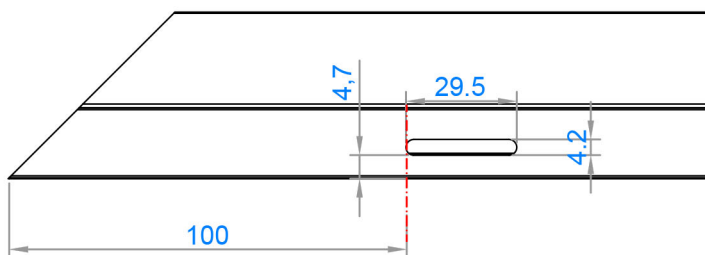
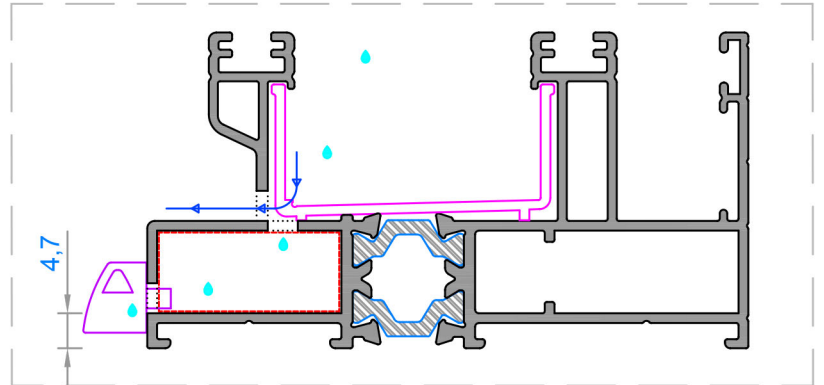
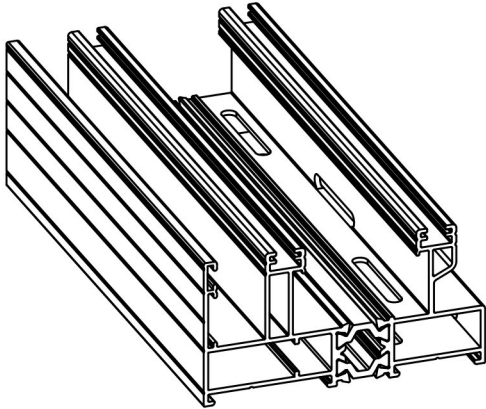
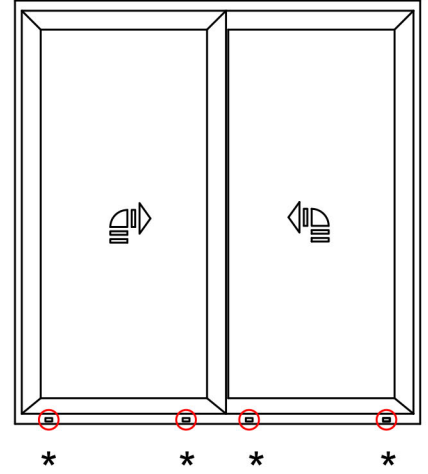
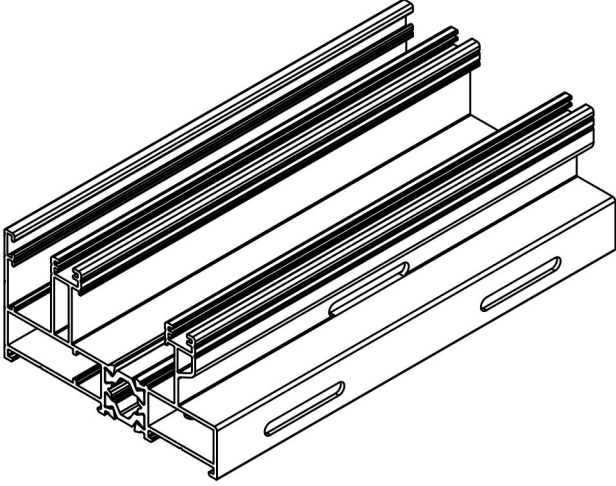

AKSESUAR MONTAJ ŞEMASI - ACCESSORY ASSEMBLY SCHEME

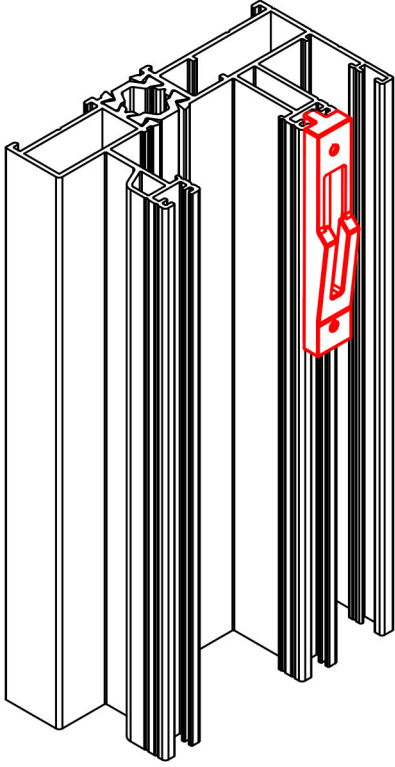

SS-AKS-07

Kilit karşılığı kasa profilleri köşe birleştirme işlemi yapılmadan önce yerine takılmalı.

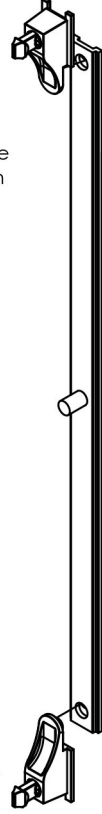

SS-AKS-06

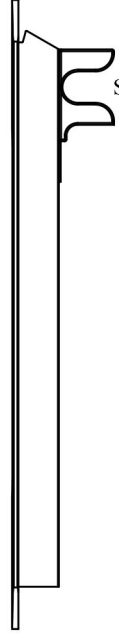

SS-AKS-08

SS-AKS-07

SS-AKS-07

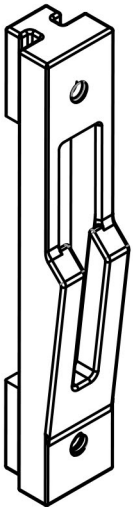

Kilit karşılığı kasa profilleri köşe birleştirme işlemi yapılmadan önce yerine takılmalı.

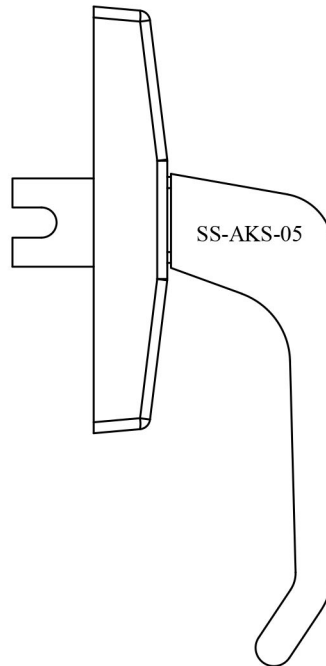

SS-AKS-05

90° KANAT MONTAJ ŞEMASI - SASH ASSEMBLY SCHEME

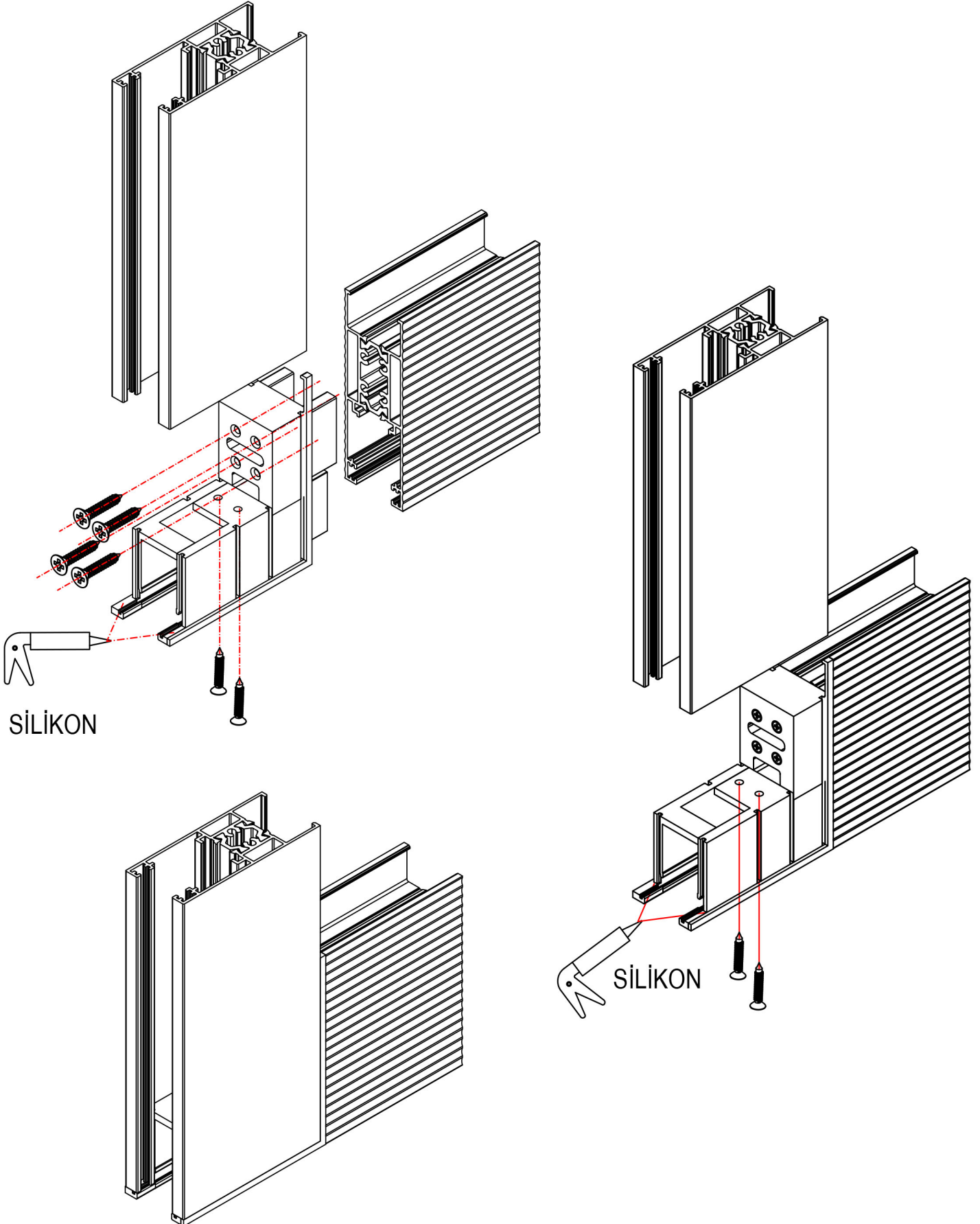



90° KANAT MONTAJ ŞEMASI - SASH ASSEMBLY SCHEME

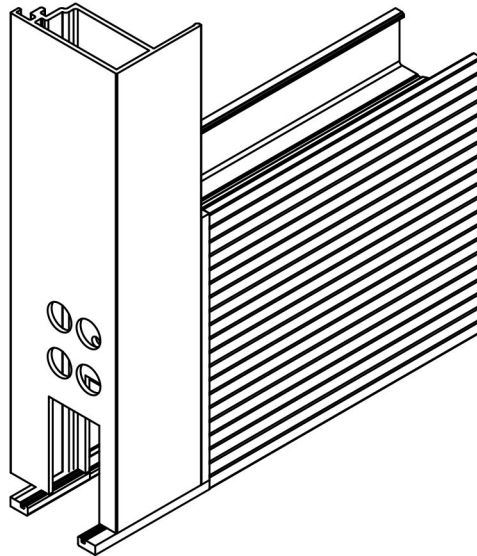
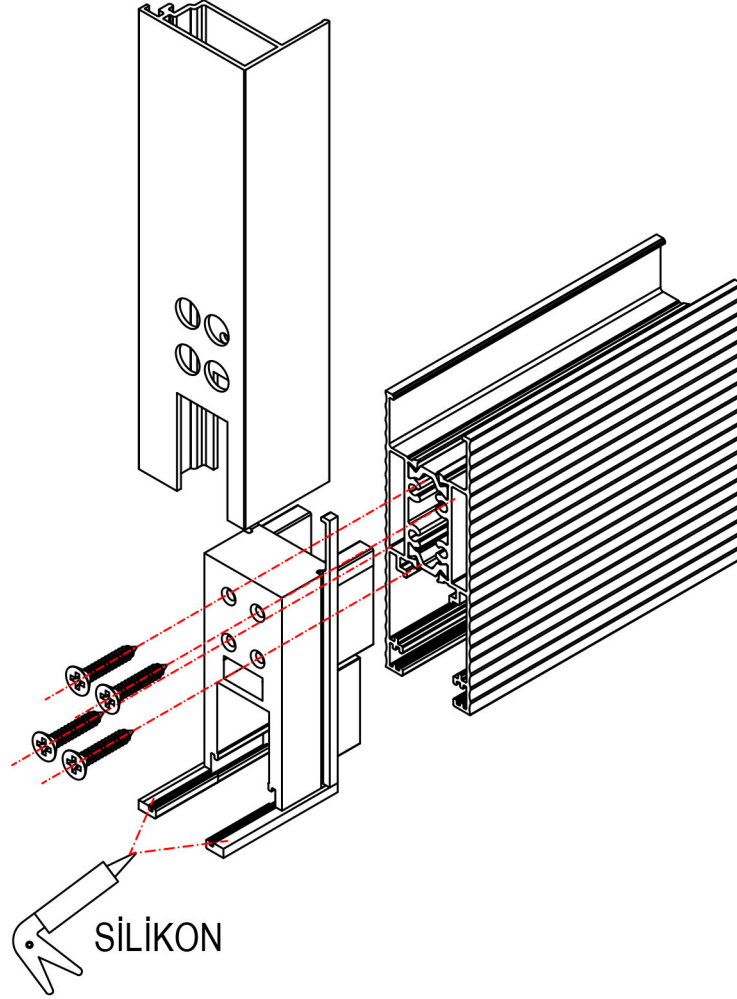

45° KANAT MONTAJ ŞEMASI - SASH ASSEMBLY SCHEME

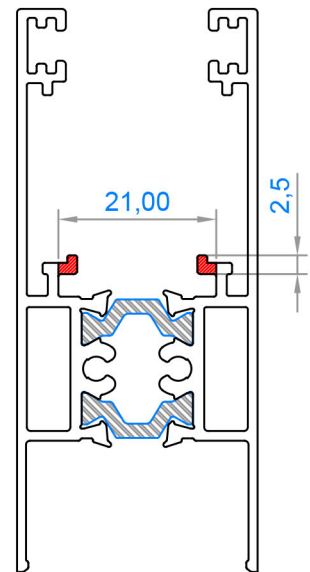
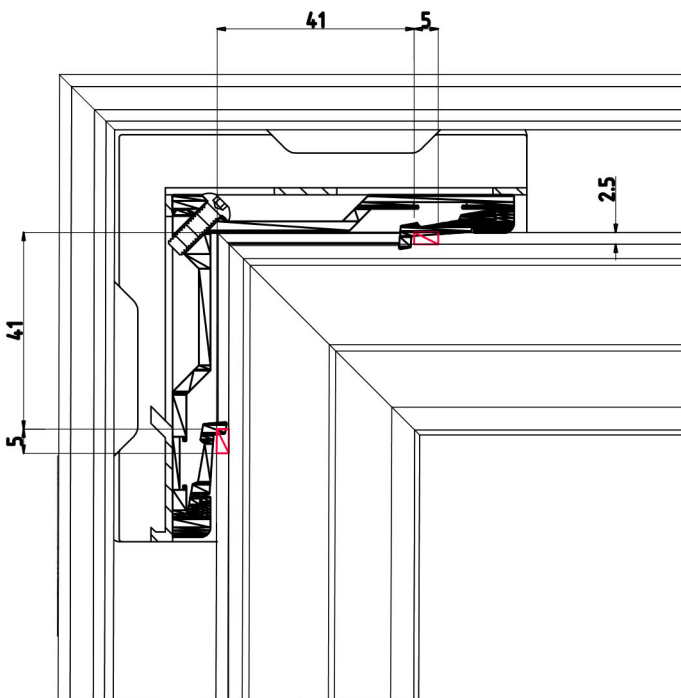
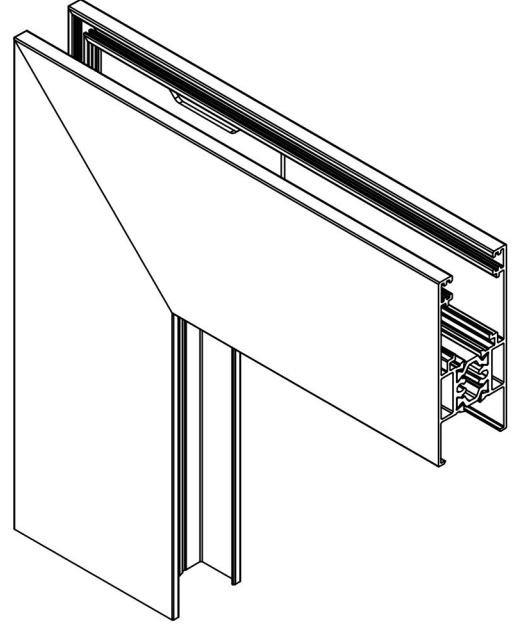
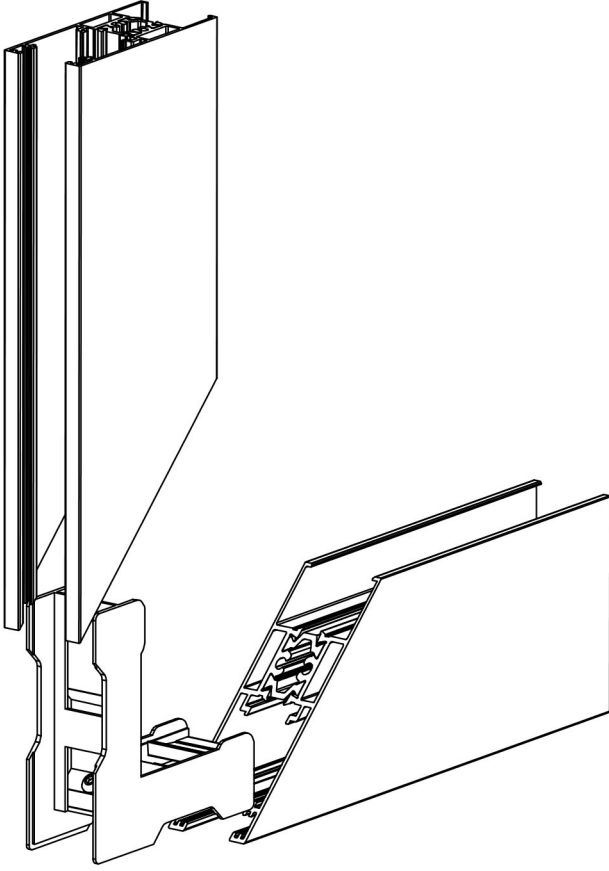

KANAT MONTAJ ŞEMASI - SASH ASSEMBLY SCHEME

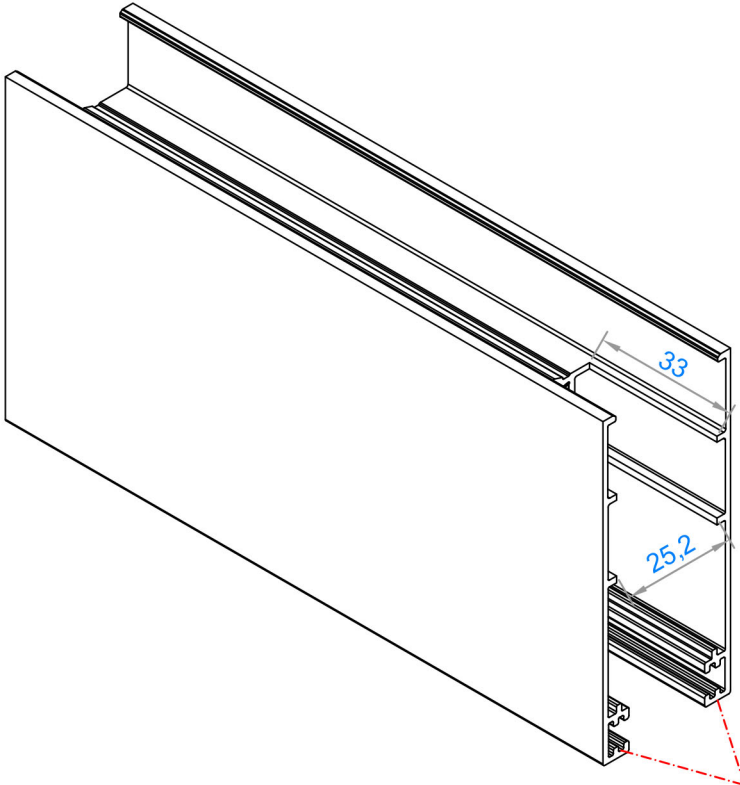
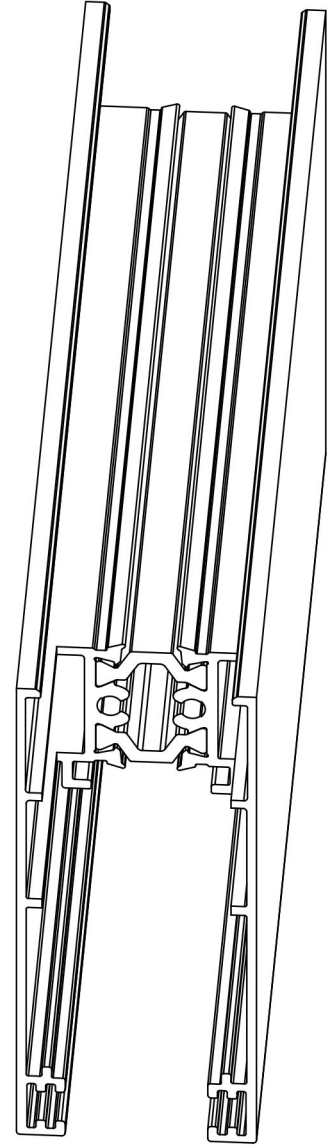
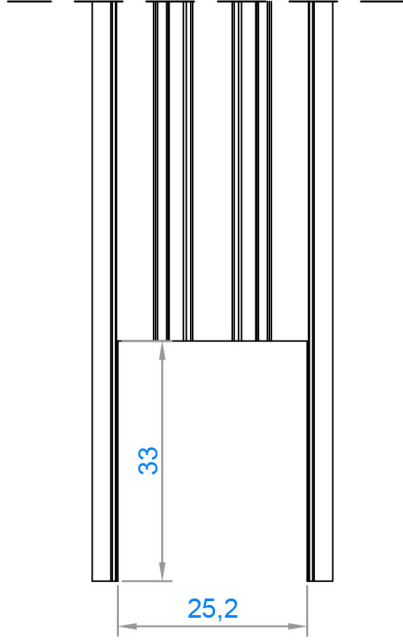

KERTME YAPILIRKEN  
FİTİL YERLERİNE DİKKAT EDİLECEK

KENET KAPAĞI MONTAJ ŞEMASI - LOCKING COVER ASSEMBLY SCHEME

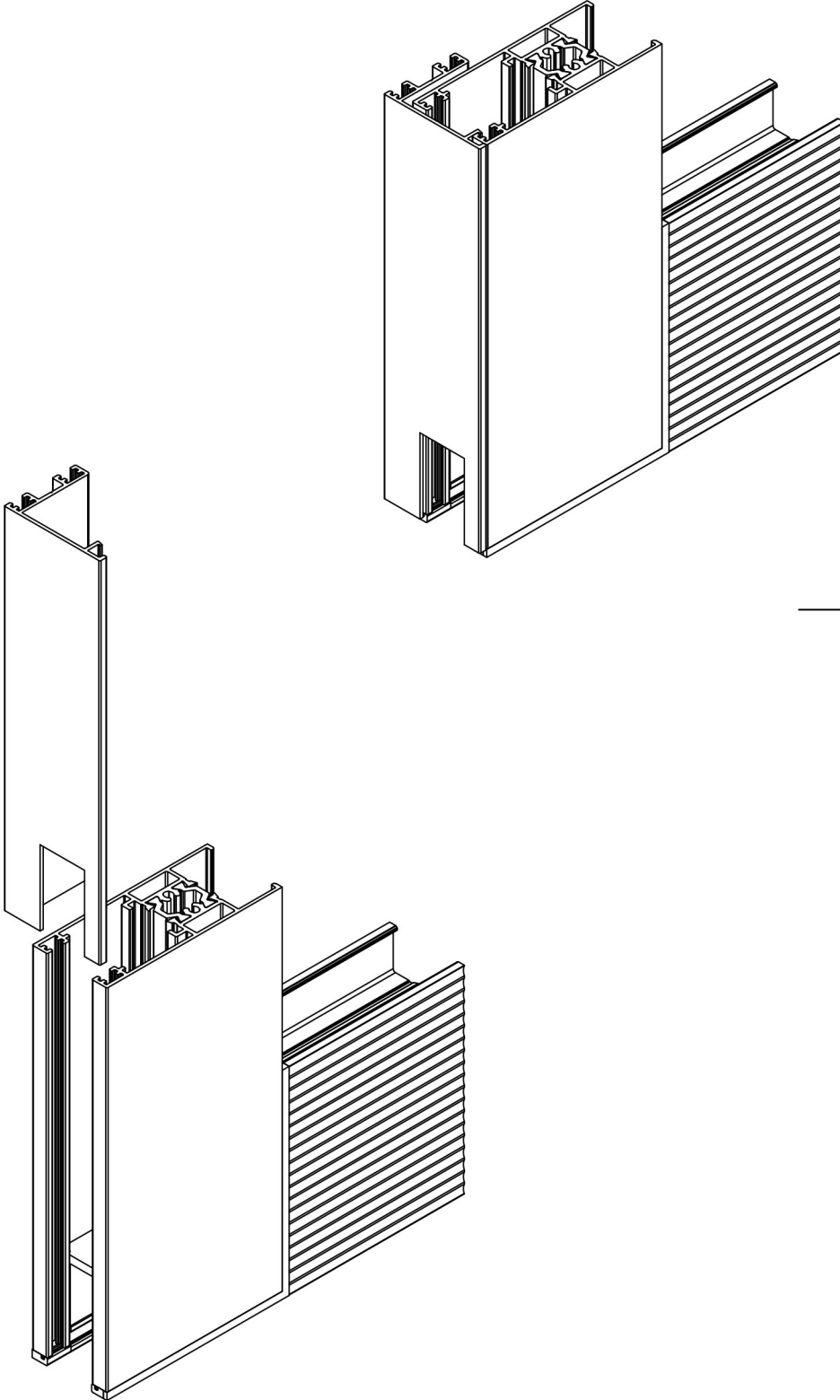

KOL MONTAJ ŞEMASI - HANDLE ASSEMBLY SCHEME

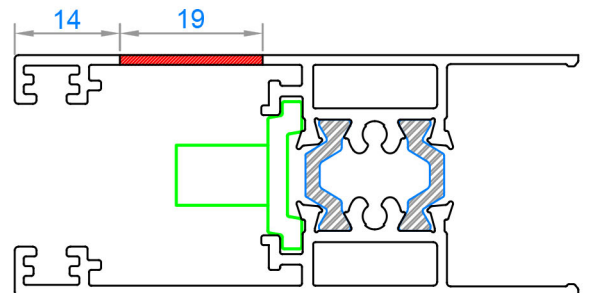
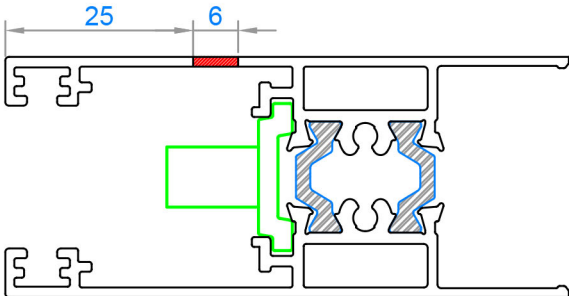
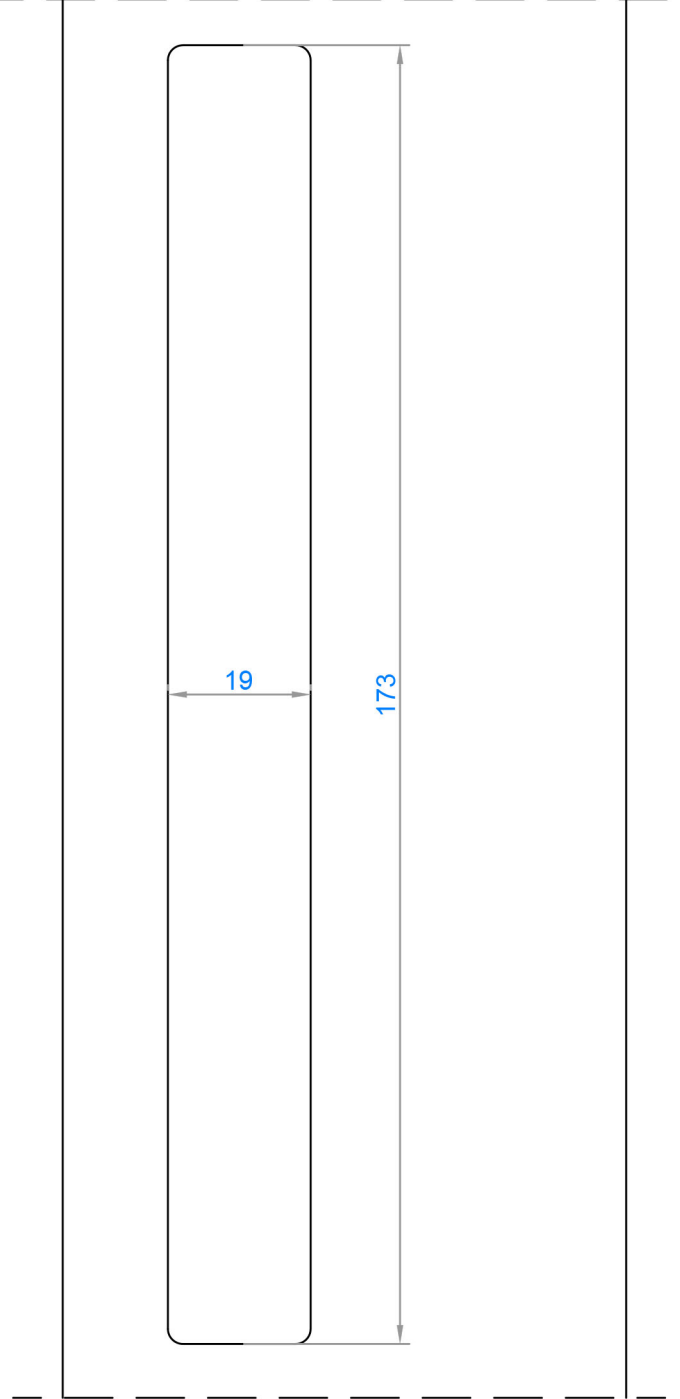
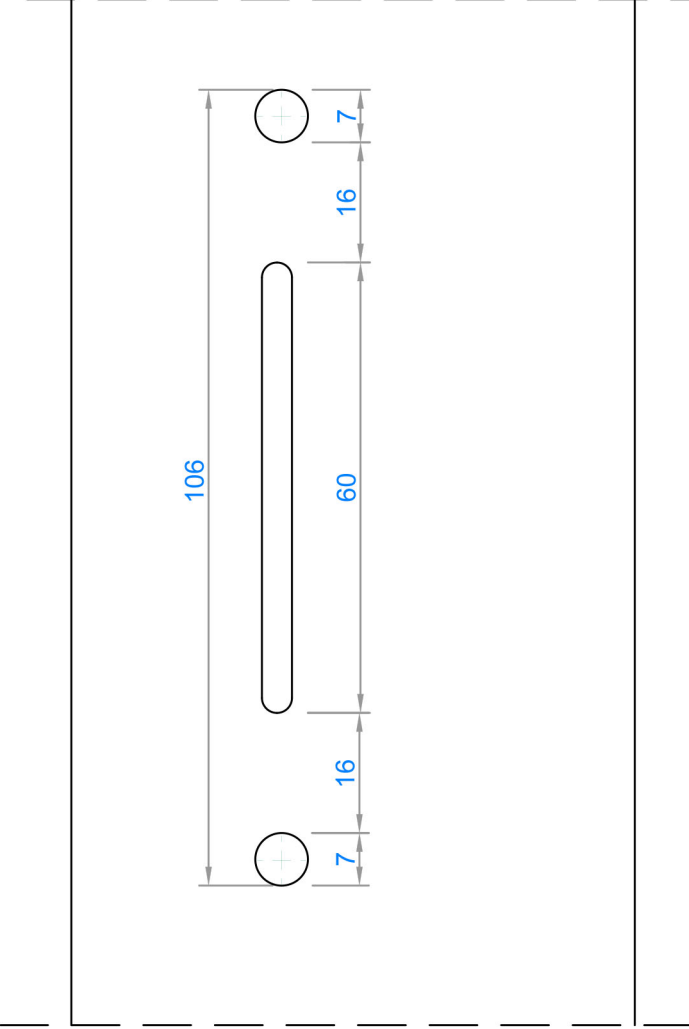

KENET MONTAJ ŞEMASI - LOCKING ASSEMBLY SCHEME

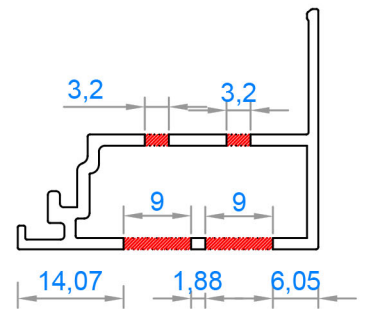
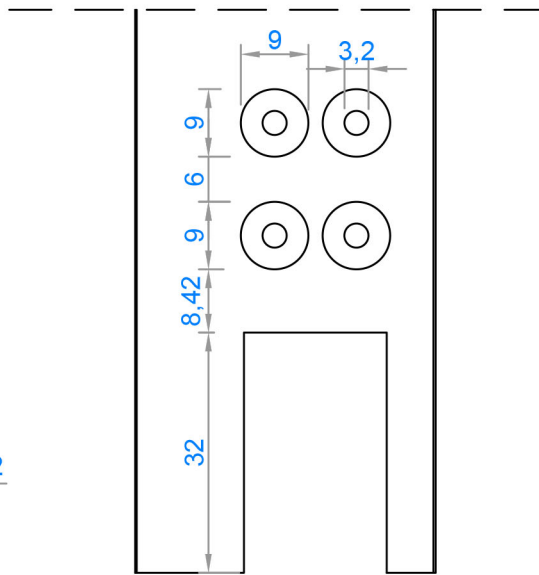
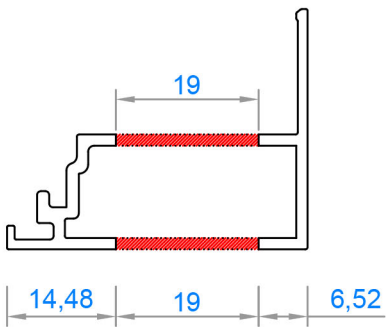
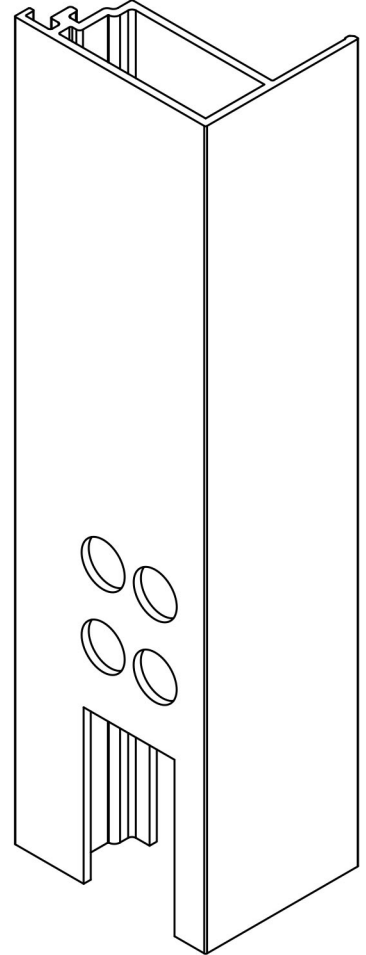
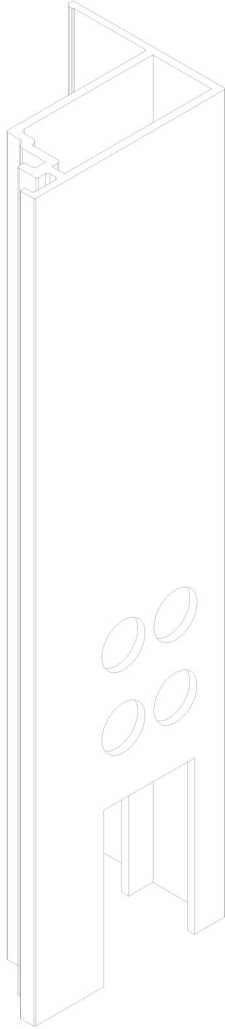

KENET MONTAJ ŞEMASI - LOCKING ASSEMBLY SCHEME

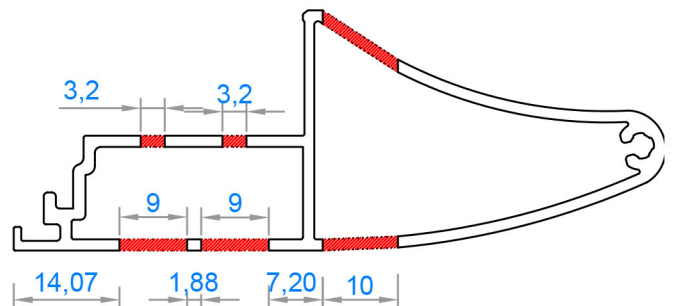
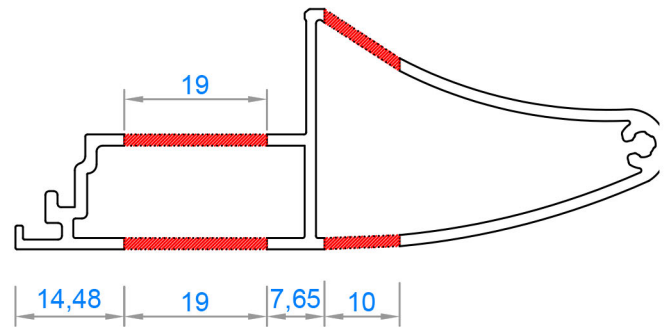
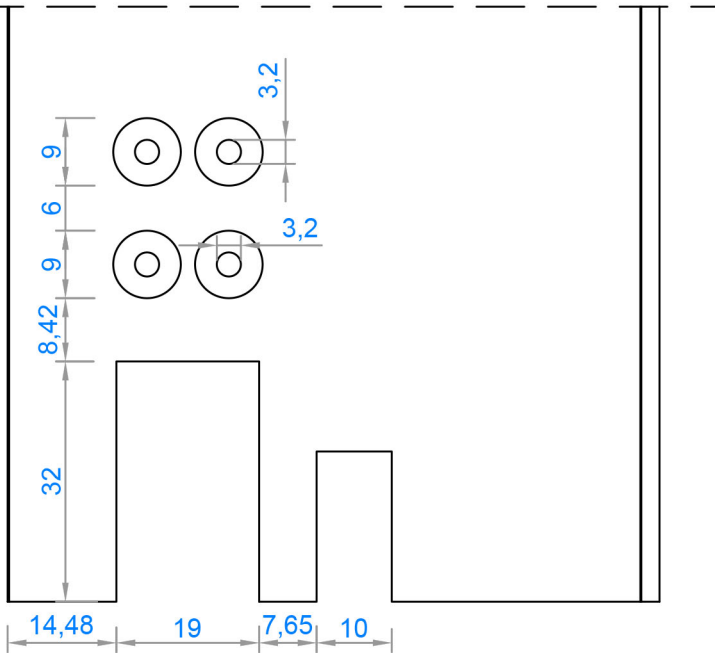
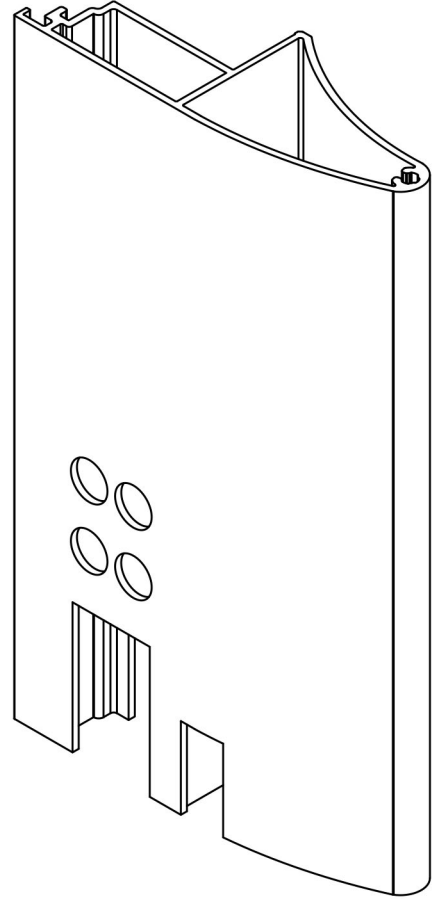
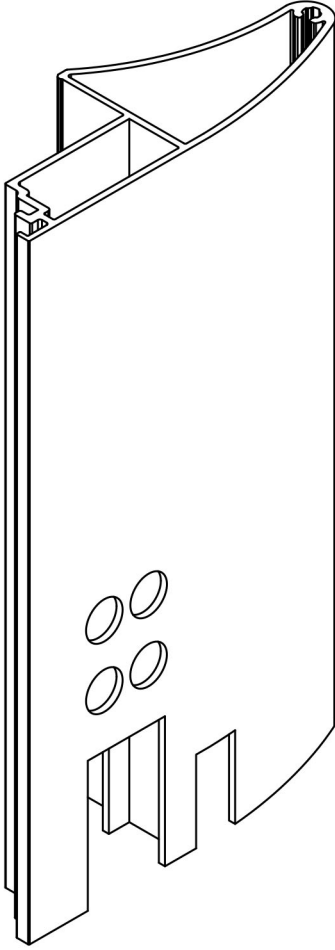

PVC İSPANYOLET MONTAJI - PVC LOCKING ASSEMBLY SCHEME

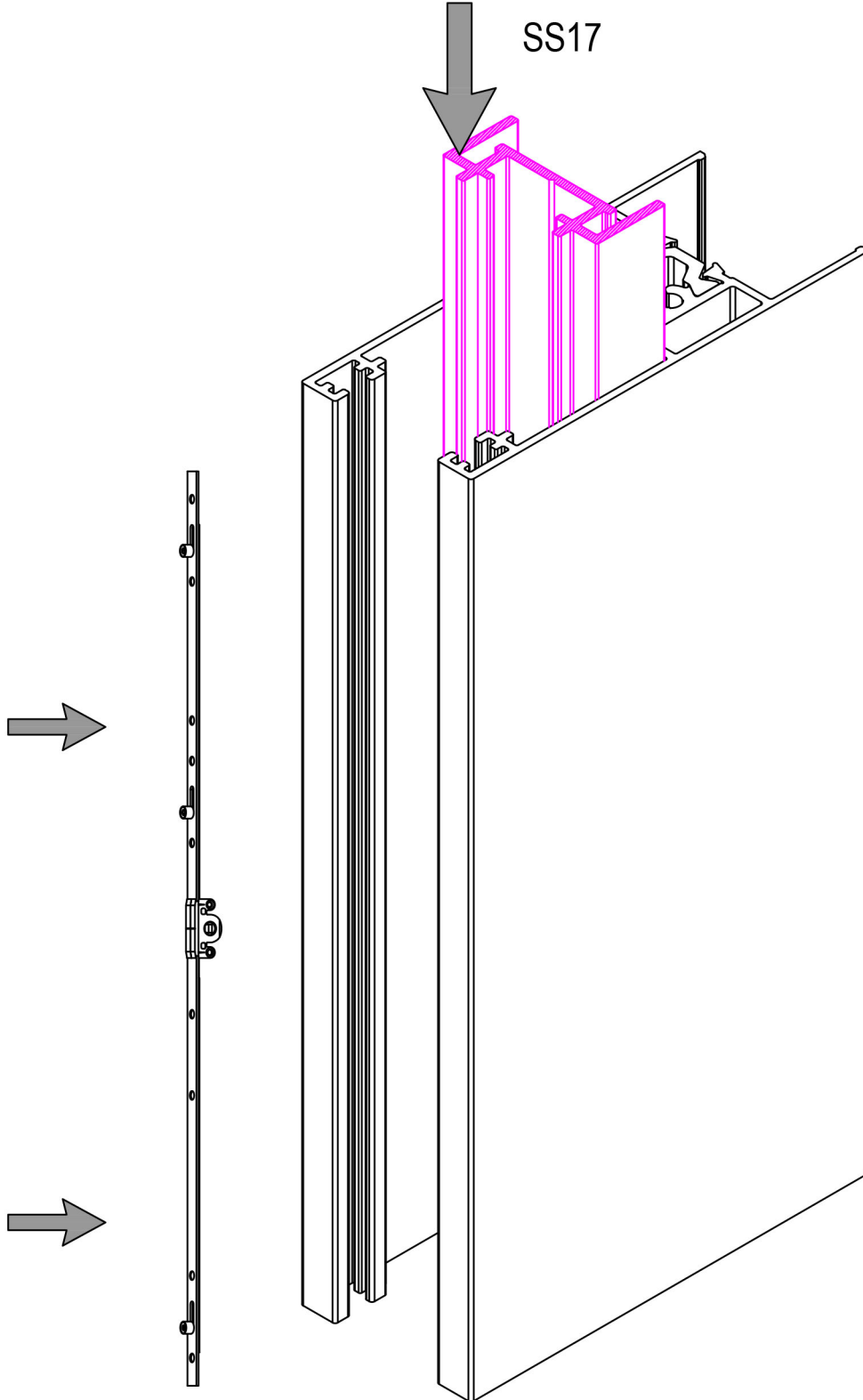



KENET MONTAJ ŞEMASI - LOCKING ASSEMBLY SCHEME

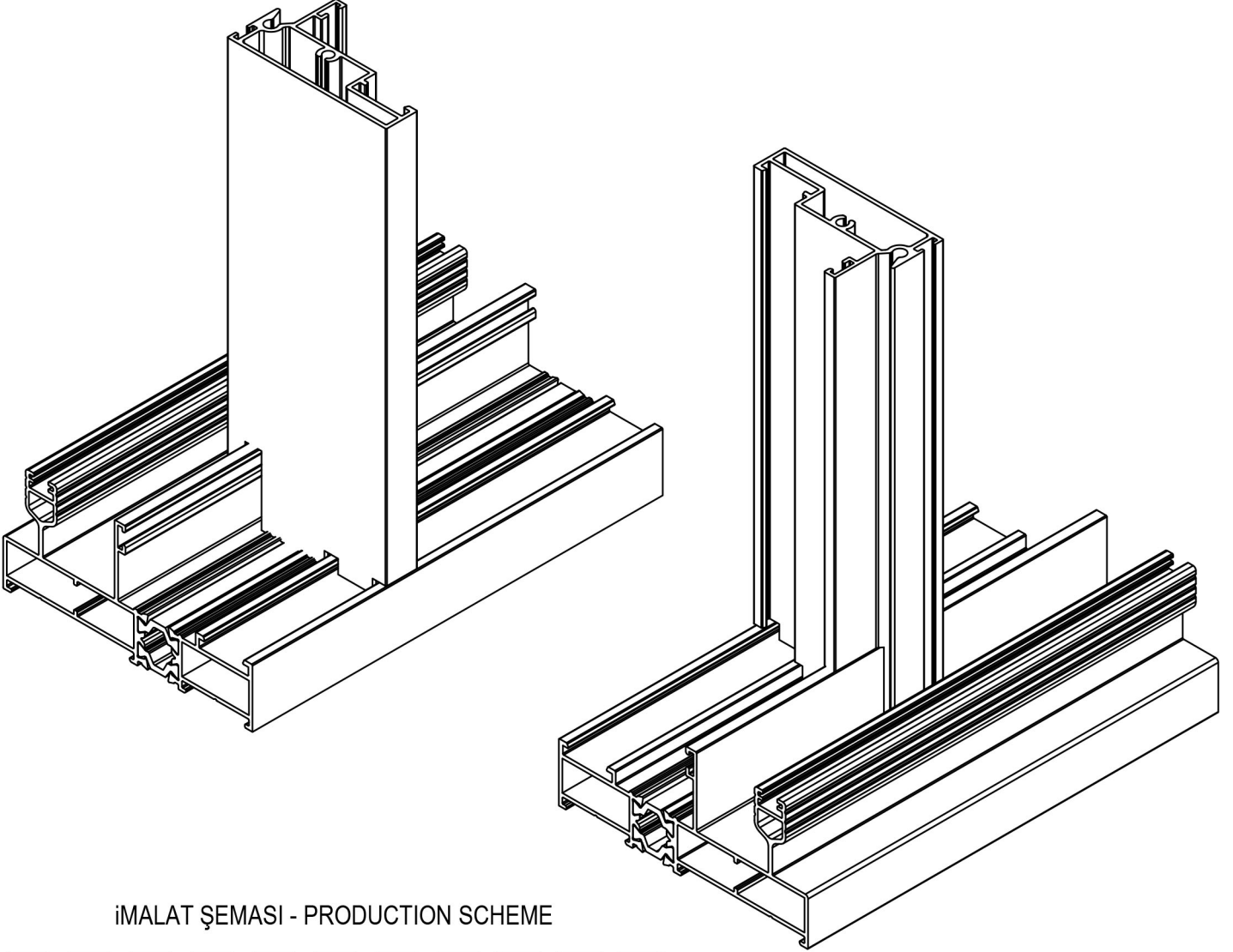

İMALAT ŞEMASI - PRODUCTION SCHEME

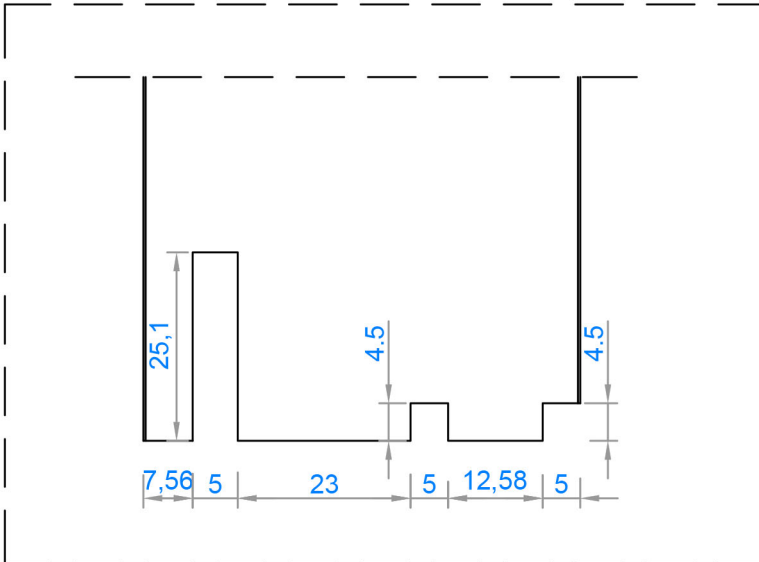

İMALAT ŞEMASI - PRODUCTION SCHEME

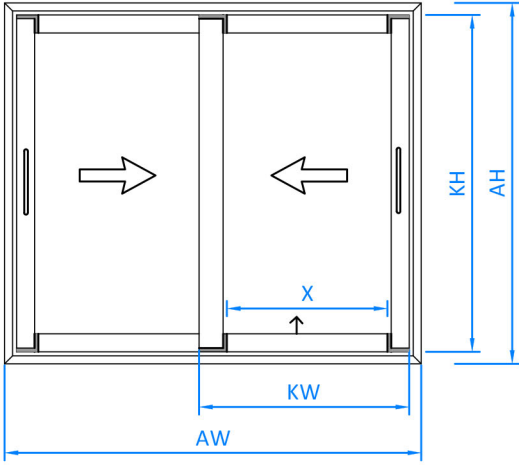

$$KW = (AW + 3,6\text{mm}) / 2$$

$$CW = KW - 125\text{mm}$$

$$X = KW - 156\text{mm}$$

$$KH = AH - 68\text{mm}$$

$$CH = KH - 155\text{mm}$$

$$DPH = AH - 6\text{mm}$$

AW = KASA GENİŞLİK-FRAME WIDTH  
AH = KASA YÜKSEKLİK-FRAME HEIGHT  
KW = KANAT GENİŞLİK-SASH WIDTH  
KH = KANAT YÜKSEKLİK-SASH HEIGHT  
DPH= DÜŞEY PROFİLYÜKSEKLİK-WERTICAL PROFILE HEIGHT  
CW = CAM GENİŞLİK-GLASS WIDTH  
CH = CAM YÜKSEKLİK-GLAS HEIGHT  
X = BAZA GENİŞLİK-SASH WIDTH

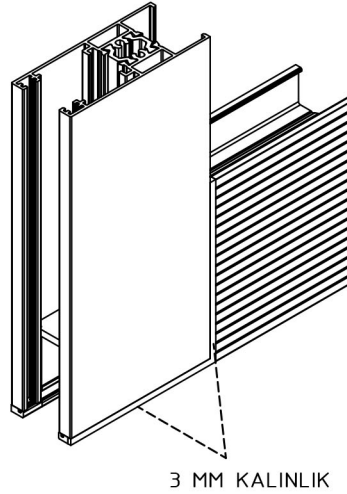

3 MM KALINLIK

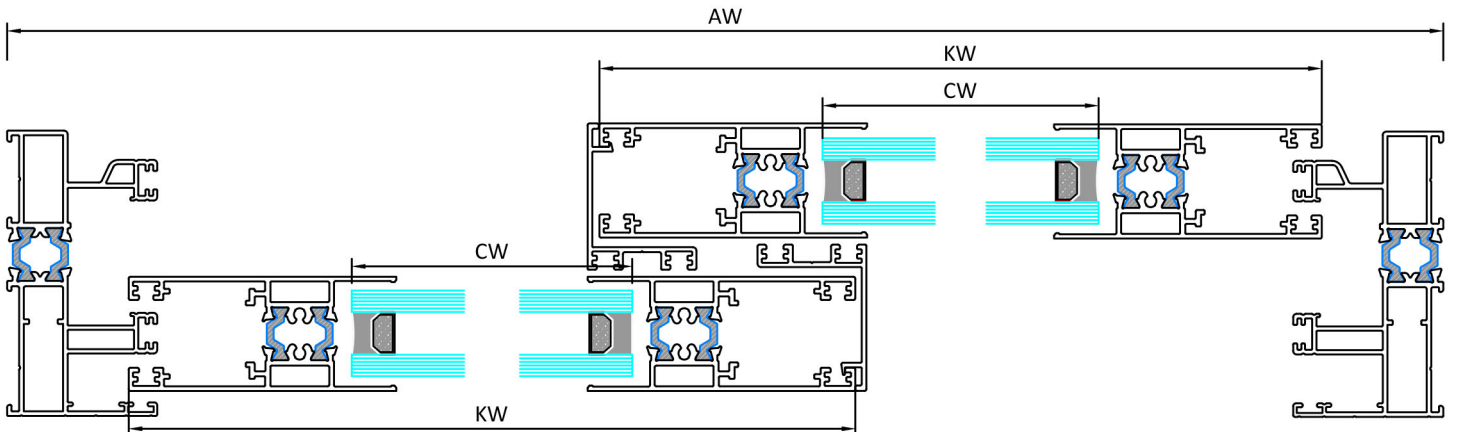
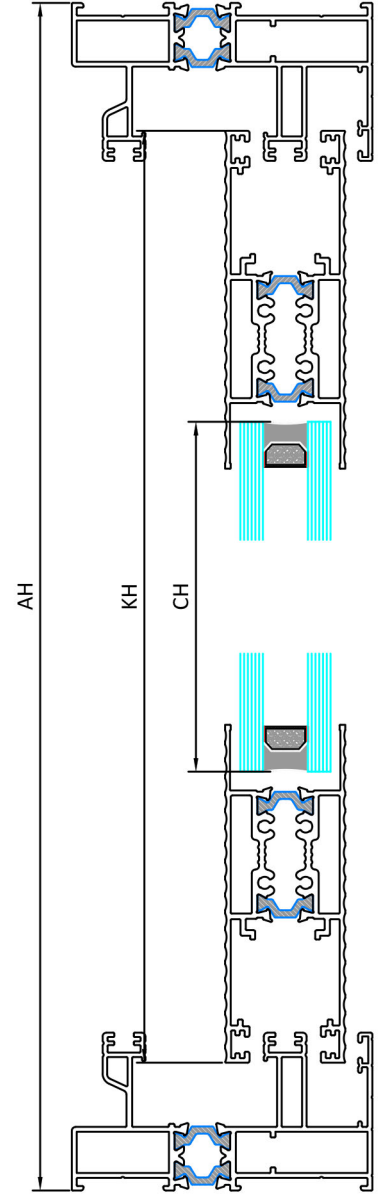

İMALAT ŞEMASI - PRODUCTION SCHEME

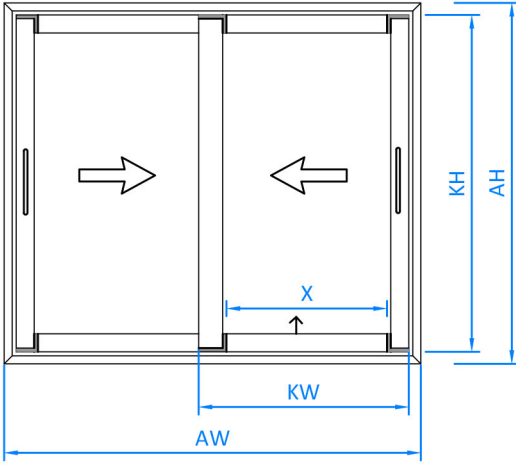

$$KW = (AW + 36\text{mm}) / 2$$

$$CW = KW - 83\text{mm}$$

$$X = KW - 113\text{mm}$$

$$KH = AH - 68\text{mm}$$

$$CH = KH - 155\text{mm}$$

$$DPH = AH - 6\text{mm}$$

AW = KASA GENİŞLİK-FRAME WIDTH  
AH = KASA YÜKSEKLİK-FRAME HEIGHT  
KW = KANAT GENİŞLİK-SASH WIDTH  
KH = KANAT YÜKSEKLİK-SASH HEIGHT  
DPH = DÜŞEY PROFİL YÜKSEKLİK-VERTICAL PROFILE HEIGHT  
CW = CAM GENİŞLİK-GLASS WIDTH  
CH = CAM YÜKSEKLİK-GLASS HEIGHT  
X = BAZA GENİŞLİK-SASH WIDTH

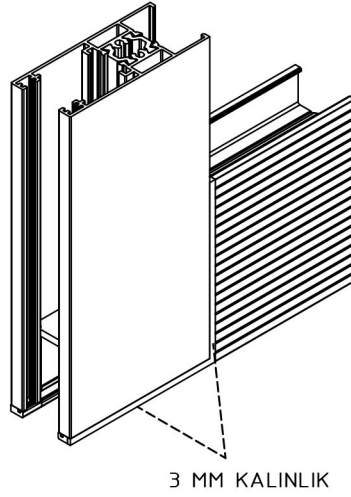

3 MM KALINLIK

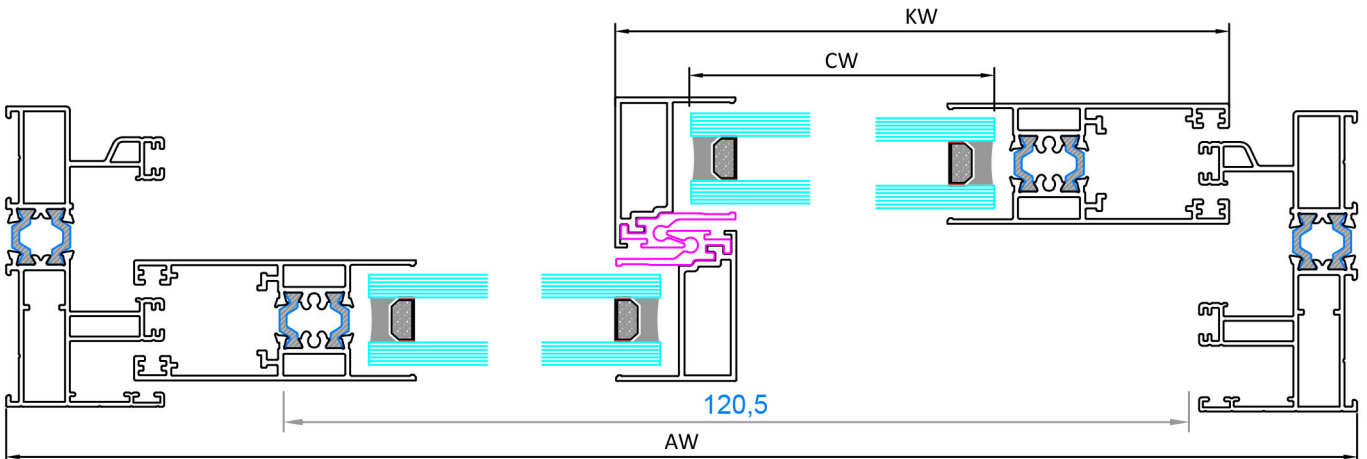
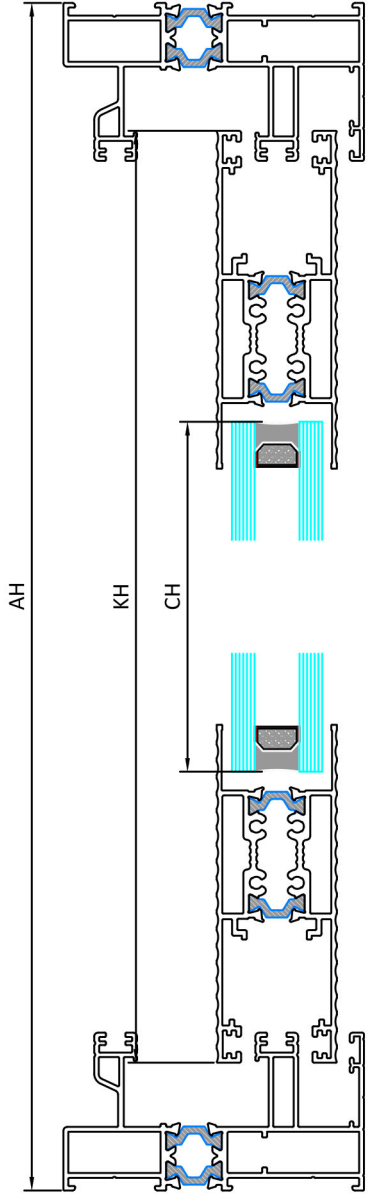

İMALAT ŞEMASI - PRODUCTION SCHEME

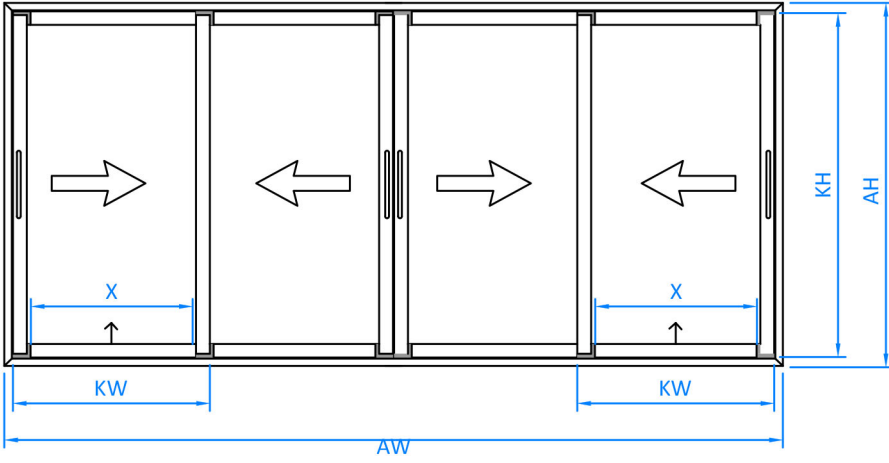

$$KW = (AW + 68\text{mm}) / 4$$

$$CW = KW - 125\text{mm}$$

$$X = KW - 156\text{mm}$$

$$KH = AH - 68\text{mm}$$

$$CH = KH - 155\text{mm}$$

$$DPH = AH - 6\text{mm}$$

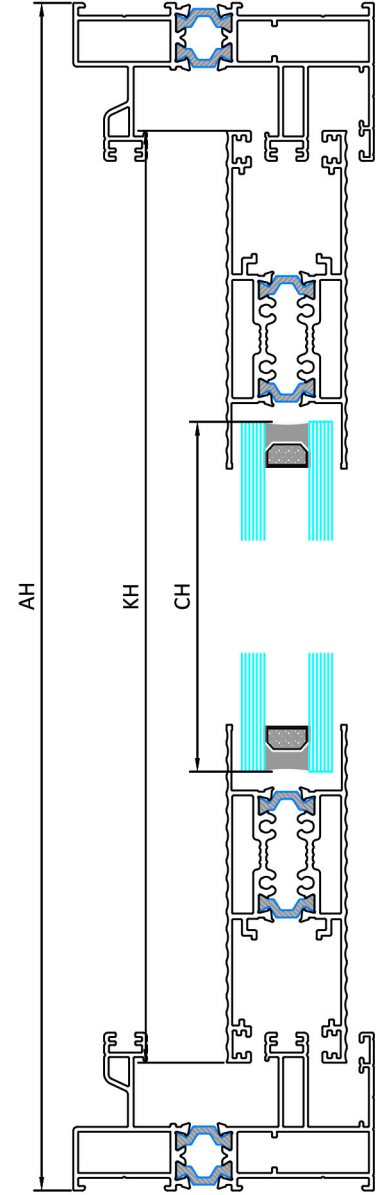
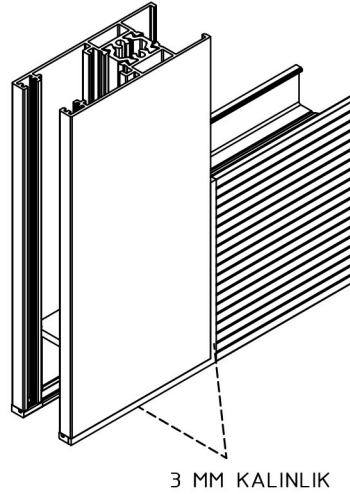

- AW = KASA GENİŞLİK-FRAME WIDTH  
 AH = KASA YÜKSEKLİK-FRAME HEIGHT  
 KW = KANAT GENİŞLİK-SASH WIDTH  
 KH = KANAT YÜKSEKLİK-SASH HEIGHT  
 DPH= DÜŞEY PROFİLYÜKSEKLİK-WERTICAL PROFILE HEIGHT  
 CW = CAM GENİŞLİK-GLASS WIDTH  
 CH = CAM YÜKSEKLİK-GLAS HEIGHT  
 X = BAZA GENİŞLİK-SASH WIDTH

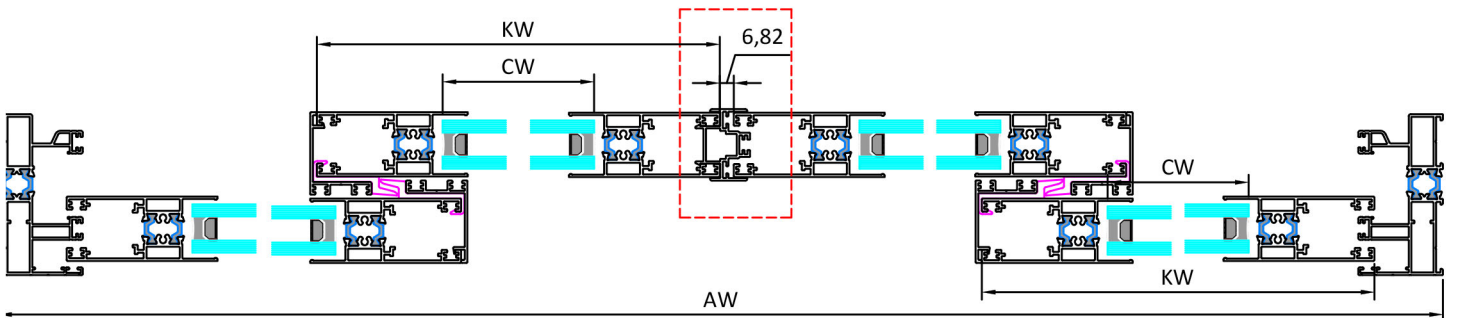

### İMALAT ŞEMASI - PRODUCTION SCHEME

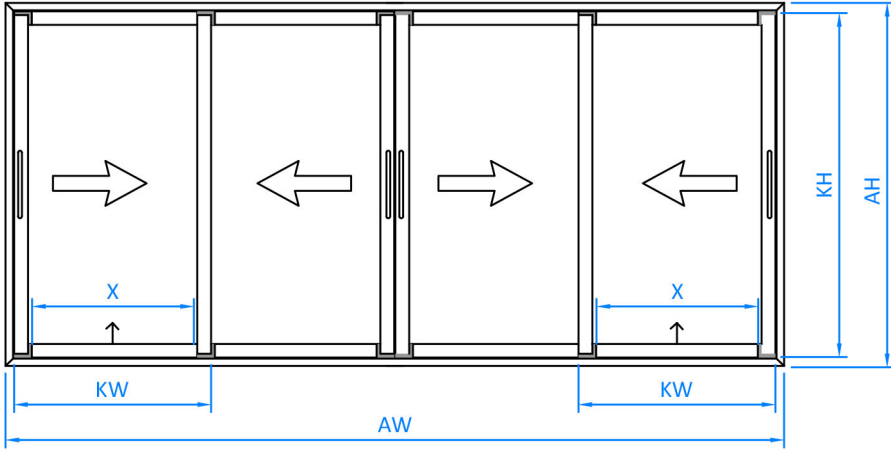

$$KW = (AW - 10\text{mm}) / 4$$

$$CW = KW - 83\text{mm}$$

$$X = KW - 113\text{mm}$$

$$KH = AH - 68\text{mm}$$

$$CH = KH - 155\text{mm}$$

$$DPH = AH - 6\text{mm}$$

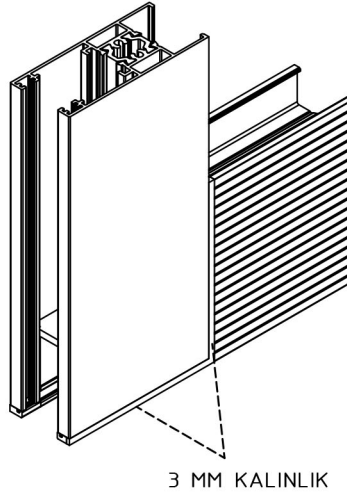



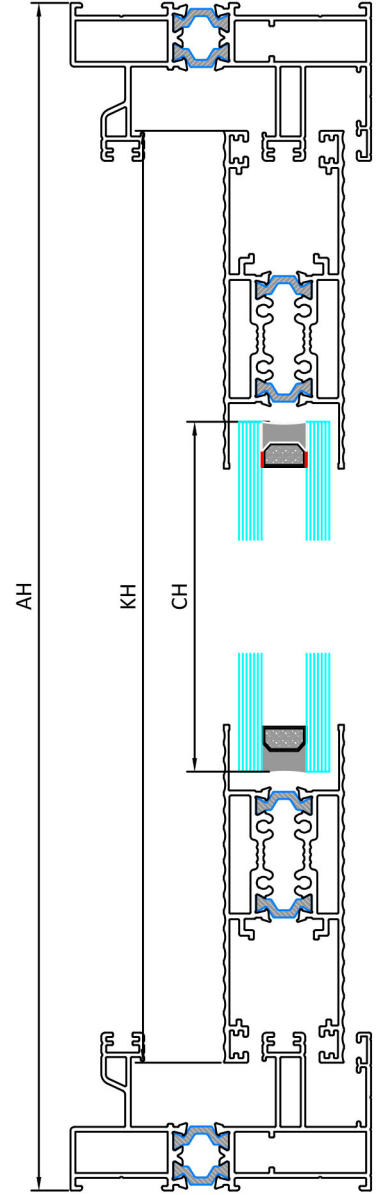



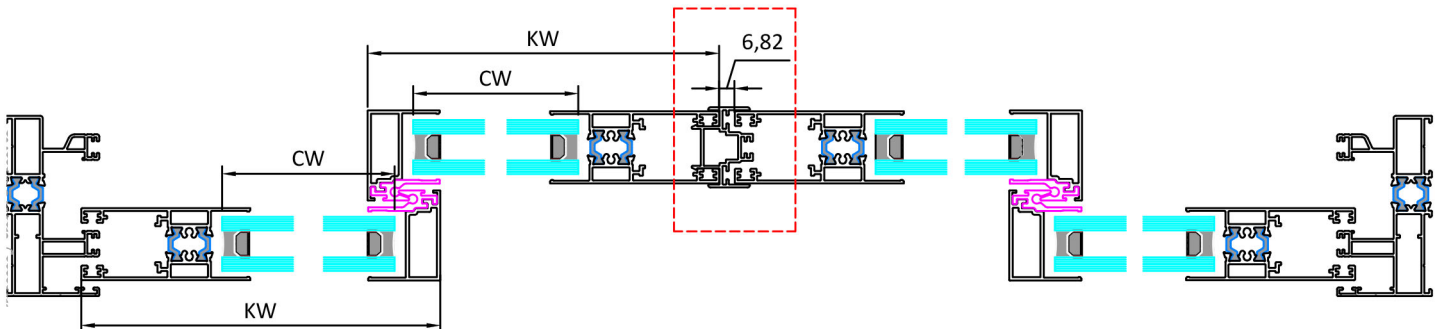

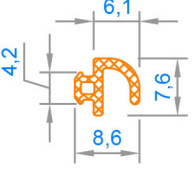

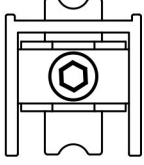

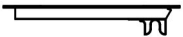
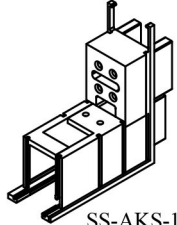
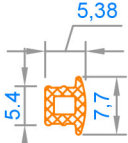
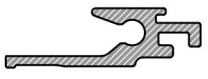
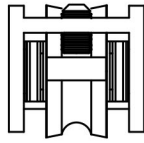
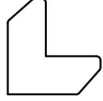

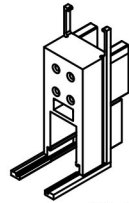
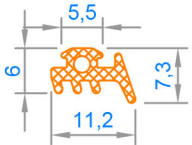
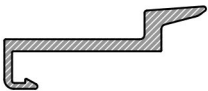
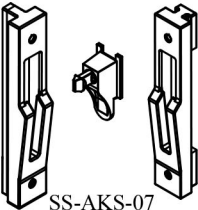
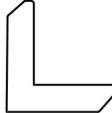
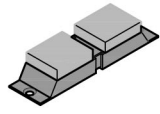
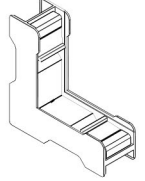
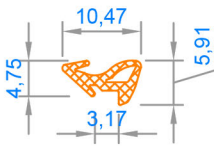
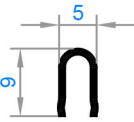
3 MM KALINLIK

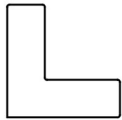
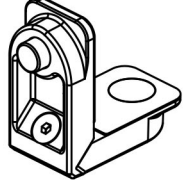
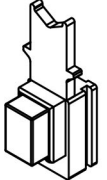
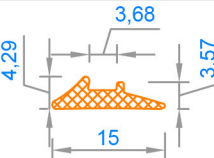

AW = KASA GENİŞLİK-FRAME WIDTH  
AH = KASA YÜKSEKLİK-FRAME HEIGHT  
KW = KANAT GENİŞLİK-SASH WIDTH  
KH = KANAT YÜKSEKLİK-SASH HEIGHT  
DPH = DÜŞEY PROFİL YÜKSEKLİK-VERTICAL PROFILE HEIGHT  
CW = CAM GENİŞLİK-GLASS WIDTH  
CH = CAM YÜKSEKLİK-GLASS HEIGHT  
X = BAZA GENİŞLİK-SASH WIDTH



 <p>C01 EPDM FİTİL EPDM GASKET</p>	 <p>B4435 KASA "U" PLASTİĞİ FRAME "U" PLASTIC (METRE)</p>	 <p>SS-AKS-04 RULMAN - ROLLER (ADET)</p>	 <p>SS-AKS-05 EKSENEL KOL AXIAL HANDLE (ADET)</p>	 <p>SS-AKS-08 HAVUZ KOL POOL HANDLE (ADET)</p>	 <p>SS-AKS-10 90° KANAT KÖŞE TAKOZU 90° SASH CORNER JOINT (ADET)</p>
 <p>C02 EPDM FİTİL EPDM GASKET</p>	 <p>N0257 (90°) KENET KİTLEME PLASTİĞİ CENTRAL LOCKING PVC PROFILE (METRE)</p>	 <p>SS-AKS-09 RULMAN - SİNEKLİK ROLLER - FYLSCREEN (ADET)</p>	 <p>7mm x 0,9mm KÖŞE GÖNYESİ CORNER ALIGNMENT (ADET)</p>	 <p>SS-AKS-03 KENET KAPAKGI CLAMP COVER (1 TAKIM ALT &amp; ÜST)</p>	 <p>SS-AKS-11 90° KENET KÖŞE TAKOZU 90° LOCKING CORNER JOINT (ADET)</p>
 <p>C03 EPDM FİTİL EPDM GASKET</p>	 <p>B8802 (45°) KENET KİTLEME PLASTİĞİ CENTRAL LOCKING PVC PROFILE (METRE)</p>	 <p>SS-AKS-07 KİLİT &amp; KARŞILIK LOCK &amp; COUNTER (1 KANAT TAKIM)</p>	 <p>28mm x 1,5mm KÖŞE GÖNYESİ CORNER ALIGNMENT (ADET)</p>	 <p>SS-AKS-02 SIZDIRMAZLIK PARÇASI TIGHTNESS PART (ADET)</p>	 <p>SS-AKS-12 45° KÖŞE TAKOZU 45° CORNER JOINT (ADET)</p>
 <p>C04 EPDM FİTİL EPDM GASKET</p>	 <p>SS-AKS-01 ÇELİK RAY STEEL RAIL (METRE)</p>	 <p>SS-AKS-06K KAPI TİJ PROFİLİ DOOR TİJ PROFILE (150 cm) (171 cm &amp; 300 cm) (ADET)</p>	 <p>15mm x 1,2mm KÖŞE GÖNYESİ CORNER ALIGNMENT (ADET)</p>	 <p>RS-1125 ALYAN KÖŞE CORNER JOINT</p>	 <p>SS-AKS-13 STOPER STOPPER (ADET)</p>
 <p>C05 EPDM FİTİL EPDM GASKET</p>	 <p>KIL-67 / 500    <p>KIL-67 / 700 KIL FİRİL BRUS GASKET</p> </p>	 <p>SS-AKS-06P KAPI TİJ PROFİLİ WINDOW TİJ PROFILE (75 cm) (0 cm &amp; 170 cm) (ADET)</p>		 <p>AS-219 ALYAN KÖŞE CORNER JOINT</p>	 <p>SS-AKS-14 KENET KAPAK LOCKING COVER (1 TAKIM ALT &amp; ÜST)</p>